

# ISOMETER® iso685

Insulation monitoring device for unearthed AC, AC/DC and DC systems (IT systems)



# ISOMETER® iso685

Insulation monitoring device for unearthed AC, AC/DC and DC systems (IT systems)



ISOMETER® iso685-D

## Device features

- Insulation monitoring for unearthed systems AC, 3(N)AC 0...690 V, DC 0...1000 V
- Nominal system voltage expandable via coupling devices
- Two separately adjustable response values 1 kΩ...10 MΩ
- Combination of **AMP<sup>PLUS</sup>** and other profile-specific measurement methods
- Continuous measurement of capacitance, voltage and system frequency
- Predefined measurement profiles to meet different requirements
- Automatic adaptation to the system leakage capacitance
- INFO button to display device and network settings
- Self-monitoring with automatic alarm message
- History memory with real-time clock (buffer for three days) for storing 1023 alarm messages with date and time
- Current and voltage output 0(4)...20 mA, 0...400 μA, 0...10 V, 2...10 V (galvanically separated) which is analogous to the measured insulation value of the system
- Permanent coupling monitoring of the measuring lines
- Freely configurable digital and analogue inputs and outputs
- Two separate alarm relays with potential-free contact
- N/O or N/C operation selectable
- High-resolution graphic LC display
- IsoGraph function for time-related representation of the insulation resistance
- Remote setting of certain parameters via Internet (web server/option; COMTRAXX® Gateway)
- Worldwide remote diagnosis via Internet
- Modbus TCP, web server and BCOM
- Multilingual

## Product description

The ISOMETER® iso685-D is an insulation monitoring device for IT systems in accordance with IEC 61557-8. It is universally applicable in AC, 3(N)AC, AC/DC and DC systems. AC systems may include extensive DC-supplied loads (such as rectifiers, inverters, variable-speed drives).

## Application

- AC, DC or AC/DC main circuits
- AC/DC main circuits with directly connected DC components, such as rectifiers, converters, regulated drives
- UPS systems, battery systems
- Heaters with phase control
- Systems including switch-mode power supplies
- IT systems with high leakage capacitances

## Function

The insulation monitoring device iso685-D continuously monitors the entire insulation resistance of an IT system during operation and triggers an alarm when the value falls below a preset response value. To obtain a measurement, the device has to be connected between the IT system (unearthed system) and the protective earth conductor (PE). A measuring current in the μA range is superimposed onto the system which is recorded and evaluated by a micro-controlled measuring circuit. The measuring time is dependent on the selected measurement profiles, the system leakage capacitance, the insulation resistance and possible system-related disturbances.

The response values and other parameters are set using a commissioning wizard or via different setup menus using the device buttons and a high-resolution graphic LC display. The selected settings are stored in a permanent fail-safe memory. Different languages can be selected for the setup menus as well as the messages indicated on the display.

The device utilises a real-time clock for storing fault messages and events in a history memory with time and date stamp. The settings can be protected against unauthorised modifications by a password. To ensure proper functioning of connection monitoring, the device requires the setting of the system type 3AC, AC or DC and the required use of the appropriate terminals L1/+, L2, L3/-.

## Device variants

### iso685-D

The device version iso685-D features a high-resolution graphic LC display and control elements for direct operating of the device functions.

### iso685-S

The device version iso685-S neither features a display nor a control unit. It can only be used in combination with FP200 and is indirectly operated via this front panel.

### Option „W“

Device variants with Option „W“ are available for extreme climatic and mechanical conditions.

## Measurement method

**AMP<sup>Plus</sup>** The iso685 series uses the patented **AMP<sup>Plus</sup>** measurement method. This measurement method allows concise monitoring of modern power supply systems, also in case of extensive, directly connected DC components and high system leakage capacitances.

## Standards

The ISOMETER® iso685 series corresponds to the device standard: DIN EN 61557-8

## Certifications





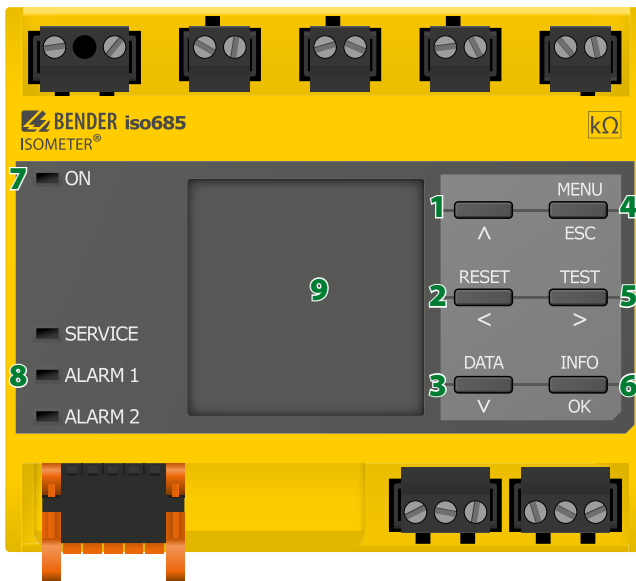

Operating elements



- 1 - "A" button: up, increase value
- 2 - "RESET" button: reset messages  
"←" button: back, select parameter
- 3 - "DATA" button: display data values  
"V" button: down, decrease value
- 4 - "MENU" button: start device menu  
"ESC" button: abort, return to the previous menu level
- 5 - "TEST" button: carry out self-test  
"→" button: forward, select parameter
- 6 - "INFO" button: display information  
"OK" button: OK, confirm
- 7 - LED "ON": operation
- 8 - LED indication "SERVICE, ALARM 1, ALARM 2"
- 9 - LC display

Ordering information

Nominal system voltage range $U_n$		Supply voltage $U_s$		Display	Option "W" <sup>1)</sup>	Type	Art. no.
AC	DC	AC	DC				
0...690 V; 1...460 Hz	0...1000 V	100...240 V; 47...460 Hz	24 V, 100...240 V	■	–	iso685-D	 B 9106 7010
				–	-40...+70 °C, 3K5, 3M7	iso685W-D <sup>1)</sup>	 B 9106 7010W
				–	–	iso685-S + FP200	 B 9106 7210
				–	-40...+70 °C, 3K5, 3M7	iso685W-S + FP200W <sup>1)</sup>	 B 9106 7210W

<sup>1)</sup> Increased shock and vibration resistance 3K5 and 3M7.

Accessories

Description	Art. no.
A set of screw terminals <sup>1)</sup>	B 9106 7901
A set of push-wire terminals	B 9106 7902
Enclosure accessories (terminal cover, 2 mounting clips) <sup>1)</sup>	B 9106 7903
Front cover 144x72 transparent (for IP65)	B 9806 0005

<sup>1)</sup> included in the scope of delivery

Suitable system components

Description	Type	Art. no.
Device version without display	iso685-S	B 9106 7110
	iso685W-S	B 9106 7110W
Display for front panel mounting	FP200	B 9106 7904
	FP200W	B 9106 7904W
Coupling devices	AGH150W-4	B 9801 8006
	AGH204S-4	B 914 013
	AGH520S	B 913 033
	AGH676S-4	B 913 055

Suitable measuring instruments on request!

**Wiring diagram**

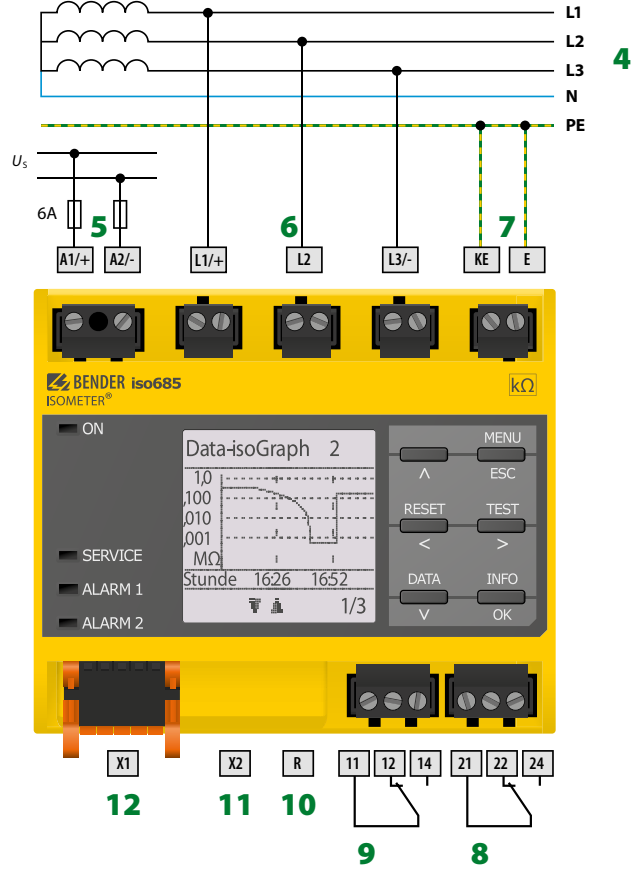
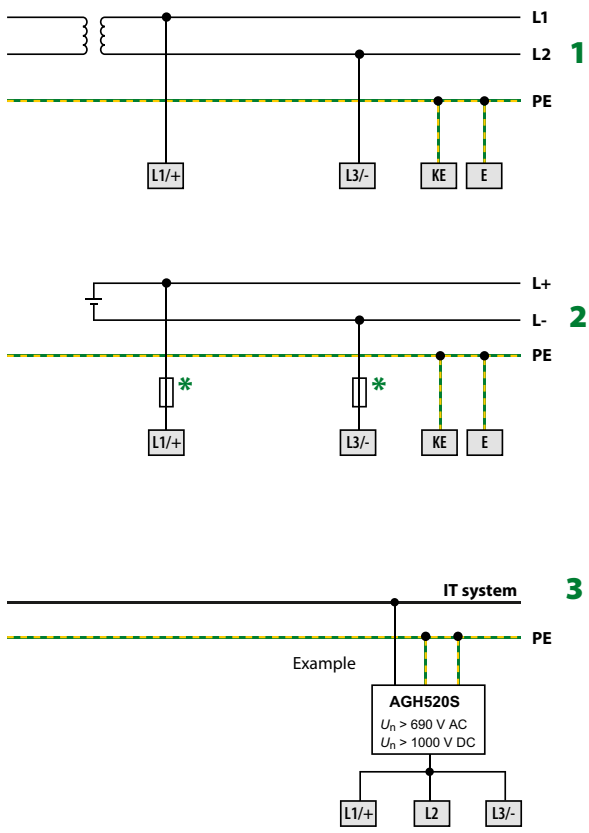

- 1 - Connection to an AC system  $U_n$
- 2 - Connection to a DC system  $U_n$
- 3 - Connection to an IT system with coupling device
- 4 - Connection to a 3(N)AC system
- 5 - Supply voltage  $U_s$  (see nameplate) via 6 A fuse
- 6 - Connection to the IT system to be monitored (L1/+, L2, L3/-)
- 7 - Separate connection of KE, E to PE

- 8 - (K1) Alarm relay 1, available changeover contacts
- 9 - (K2) Alarm relay 2, available changeover contacts
- 10 - Switchable resistor R for RS-485 bus termination
- 11 - Ethernet interface
- 12 - Digital interface

\* - 6 A fuse for systems > 690 V

**NOTE:**  
According to DIN VDE 0100-430, devices for protection against a short-circuit can be omitted for the coupling of terminals L1/+ and L3/- to the IT system  $\leq 690$  V to be monitored if the wiring is carried out in such a manner as to reduce the risk of a short-circuit to a minimum. (Recommendation: Ensure short-circuit-proof and earth-fault-proof wiring).

The connecting lines L1/+, L2, L3/- to the system to be monitored must be carried out as spur lines. No load current may be conducted through the terminals.

**For UL applications:**  
Use 60/70°C copper lines only!  
UL and CSA application require the supply voltage to be protected via 5 A fuses.

Connection to FP200

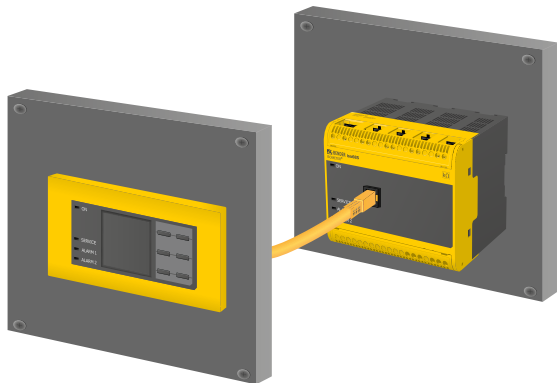

Dimension diagram

Dimensions in mm

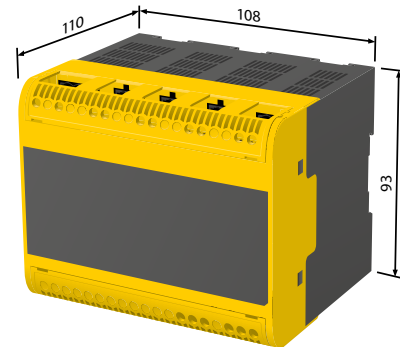

Digital interface X1

Digital interface	Terminal	Colour
<p>X1</p>	I1	Input 1
	I2	Input 2
	I3	Input 3
	A	RS-485 A
	B	RS-485 B
	+	+24V
	Q1	Output 1
	Q2	Output 2
	M+	Analogue output
	⊥	Ground

Digitale Ausgänge

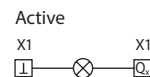
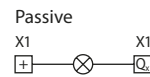

Digitale Eingänge

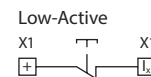
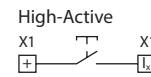

Analoger Ausgang

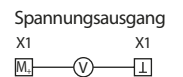
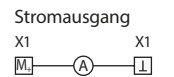

Beispiel

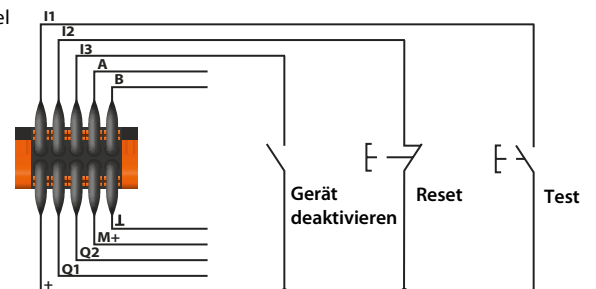

Connection to X1



CAUTION

**Danger of damage to property due to faulty connections!**

The device can be damaged if the unit is simultaneously connected to the supply voltage via the X1 interface, and A1/+, A2/- terminals. Do not connect the device simultaneously via X1, and A1/+, A2/- to different supply voltages.



CAUTION

**Danger of damage to property due to incorrect nominal voltage!**

When the device is powered via the X1 interface, the nominal voltage must be 24 V otherwise the unit may be damaged. Connect only to the X1 interface with a nominal voltage of 24 V.

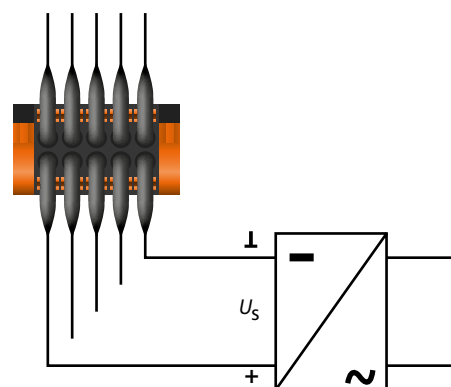

## Technical data

### Insulation coordination

Rated insulation voltage (IEC 60664-1)	1000 V
Rated impulse voltage (IEC 60664-1)	8 kV
Overvoltage category	III
Pollution degree ( $U_n < 690$ V)	3
Pollution degree ( $U_n < 1000$ V)	2
Protective separation (reinforced insulation) between (A1, A2) - (11, 12, 14) - (21, 22, 24) - [(L1/+, L2, L3/-), (E, KE), (X1, X2)]	
Voltage test, routine test (IEC 61010-1)	4.3 kV

### Supply voltage

#### Supply via A1/+, A2/-:

Supply voltage range $U_S$	AC/DC 100...240 V
Tolerance of $U_S$	AC -15...+10 % DC -15...+15 %
Frequency range of $U_S$	DC, 47...460 Hz
Power consumption, typically 50 Hz (460 Hz)	5.7 W/20 VA (7.9 W/45.5 VA)

#### Supply via X1:

Supply voltage $U_S$	DC 24 V
Tolerance of $U_S$	DC -20...+25 %

### IT system being monitored

Nominal system voltage range $U_n$	AC 0...690 V DC 0...1000 V
Tolerance of $U_n$	AC/DC +15 %
Frequency range of $U_n$	DC, 1...460 Hz

### Response values

Response value $R_{an1}$ (Alarm 1)	1 k $\Omega$ ...10 M $\Omega$ (40 k $\Omega$ )*
Response value $R_{an2}$ (Alarm 2)	1 k $\Omega$ ...10 M $\Omega$ (10 k $\Omega$ )*
Relative uncertainty (acc. to IEC 61557-8)	profile-dependent, $\pm 15$ %, min. $\pm 1$ k $\Omega$
Hysteresis	25 %, min. 1 k $\Omega$

### Time response

Response time $t_{an}$ at $R_F = 0,5 \times R_{an}$ ( $R_{an} = 10$ k $\Omega$ ) und $C_e = 1$ $\mu$ F acc. to IEC 61557-8	profile-dependent, typ. 4 s
Startup delay $T_{startup}$	0...120 s (0 s)*

### Measuring circuit

Measuring voltage $U_m$	profile-dependent, $\pm 10$ V, $\pm 50$ V
Measuring current $I_m$	$\leq 403$ $\mu$ A
Internal resistance $R_i, Z_i$	$\geq 124$ k $\Omega$
Permissible extraneous DC voltage $U_{fg}$	$\leq 1200$ V
Permissible system leakage capacitance $C_e$	dependent on the profile, 0...1000 $\mu$ F

### Measuring ranges

Measuring range $f_n$	10...460 Hz
Tolerance measurement of $f_n$	$\pm 1$ % $\pm 0.1$ Hz
Voltage range measurement of $f_n$	AC 25...690 V
Measuring range $U_n$ (without external coupling device)	AC 25...690 V DC 25...1000 V
Voltage range measurement of $U_n$	AC/DC $> 10$ V
Tolerance measurement of $U_n$	$\pm 5$ % $\pm 5$ V
Measuring range $C_e$	0...1000 $\mu$ F
Tolerance measurement of $C_e$	$\pm 10$ % $\pm 10$ $\mu$ F
Frequency range measurement of $C_e$	DC, 30...460 Hz
Min. insulation resistance measurement of $C_e$	depending on profile and coupling mode, typ. $> 10$ k $\Omega$

### Display

Indication	Graphic display 127 x 127 Pixel, 40 x 40 mm
Display range measured value	0.1 k $\Omega$ ...20 M $\Omega$

### LEDs:

ON (operation LED)	green
SERVICE	yellow
ALARM 1	yellow
ALARM 2	yellow

### Digital inputs

Number	3
Operating mode, adjustable	active high, active low
Functions	none, test, reset, start measurement, deactivate device
Voltage	Low DC -3...5 V, High DC 11...32 V

### Digital outputs

Number	2
Operating mode, adjustable	active, passive
Functions	none, Alarm 1, Alarm 2, connection fault, Alarm DC-, Alarm DC+, symmetrical insulation fault, device error, common alarm, measurement complete, device inactive
Voltage	passive DC 0...32 V, active DC 0/19.2...32 V
Max. current internal sum X1	max. 200 mA
Max. current external per channel	max. 1 A

### Analogue output

Number	1
Operating mode	linear, mid-scale 28 k $\Omega$ /120 k $\Omega$
Functions	insulation value, DC shift
Current	0...20 mA ( $< 600$ $\Omega$ ), 4...20 mA ( $< 600$ $\Omega$ ), 0...400 $\mu$ A ( $< 4$ k $\Omega$ )
Voltage	0...10 V ( $> 1$ k $\Omega$ ), 2...10 V ( $> 1$ k $\Omega$ )
Tolerance related to the current/voltage final value	$\pm 20$ %

### Interfaces

#### Field bus:

Interface/protocol	web server/Modbus TCP/BCOM
Data rate	10/100 Mbit/s, autodetect
Max. number of Modbus requests	$< 100$ /s
Cable length	$\leq 100$ m
Connection	RJ45
IP address	DHCP/manual* 192.168.0.5*
Network mask	255.255.255.0*
BCOM address	system-1-0
Function	Communication interface

#### Sensor bus:

Interface/protocol	RS-485/BS
Data rate	9.6 kBaud/s
Cable length	$\leq 1200$ m
Cable: twisted pair, one end of shield connected to PE	recommended: J-Y(St)Y min. 2x0.8
Connection	terminals X1.A, X1.B
Terminating resistor	120 $\Omega$ , can be connected internally
Device address, BS bus	1...90 (3)*

**Technical data (continued)**
**Switching elements**

Number of switching elements	2 changeover contacts				
Operating mode	N/C operation*/N/O operation				
Contact 11-12-14	none, Alarm 1, Alarm 2, connection fault, Alarm DC-, Alarm DC+, symmetrical insulation fault, device error, common alarm, measurement complete, device inactive				
Contact 21-22-24	none, Alarm 1, Alarm 2, connection fault, Alarm DC-, Alarm DC+, symmetrical insulation fault, device error, common alarm, measurement complete, device inactive				
Electrical endurance, number of cycles	10000				
Contact data acc. to IEC 60947-5-1:					
Utilisation category	AC -13	AC -14	DC-12	DC-12	DC-12
Rated operational voltage	230 V	230 V	24 V	110 V	220 V
Rated operational current	5 A	3 A	1 A	0.2 A	0.1 A
Rated insulation voltage ≤ 2000 m NN	250 V				
Rated insulation voltage ≤ 3000 m NN	160 V				
Minimum contact rating	1 mA at AC/DC ≥ 10 V				

**Environment/EMC**

EMC	IEC 61326-2-4
Ambient temperatures:	
Operating temperature	-25...+55 °C
Transport	-40...+85 °C
Langzeitlagerung	-25...+70 °C
Classification of climatic conditions acc. to IEC 60721:	
Stationary use (IEC 60721-3-3)	3K5 (except condensation and formation of ice)
Transport (IEC 60721-3-2)	2K3
Long-term storage (IEC 60721-3-1)	1K4
Classification of mechanical conditions acc. to IEC 60721:	
Stationary use (IEC 60721-3-3)	3M4
Transport (IEC 60721-3-2)	2M2
Long-term storage (IEC 60721-3-1)	1M3
Area of application	≤3000 m NN

**Connection**

Connection type	pluggable screw terminal or push-wire terminal
-----------------	--

**Screw-type terminal:**

Nominal current	≤10 A
Tightening torque	0.5...0.6 Nm (5...7 lb-in)
Conductor sizes	AWG 24...12
Stripping length	7 mm
rigid/flexible	0.2...2.5 mm <sup>2</sup>
flexible with ferrule with/without plastic sleeve	0.25...2.5 mm <sup>2</sup>
Multiple conductor rigid	0.2...1 mm <sup>2</sup>
Multiple conductor flexible	0.2...1.5 mm <sup>2</sup>
Multiple conductor flexible with ferrule without plastic sleeve	0.25...1 mm <sup>2</sup>
Multiple conductor flexible with TWIN ferrule with plastic sleeve	0.5...1.5 mm <sup>2</sup>

**Push-wire terminal:**

Nominal current	≤10 A
Conductor sizes	AWG 24...12
Stripping length	10 mm
rigid/flexible	0.2...2.5 mm <sup>2</sup>
flexible with ferrule with/without plastic sleeve	0.25...2.5 mm <sup>2</sup>
Multiple conductor, flexible with TWIN ferrule with plastic sleeve	0.5...1.5 mm <sup>2</sup>

**Push-wire terminals X1:**

Nominal current	≤8 A
Conductor sizes	AWG 24...16
Stripping length	10 mm
rigid/flexible	0.2...1.5 mm <sup>2</sup>
flexible with ferrule without plastic sleeve	0.25...1.5 mm <sup>2</sup>
flexible with ferrule with plastic sleeve	0.25...0.75 mm <sup>2</sup>

**Other**

Operating mode	Continuous operation
Mounting	Display-oriented, cooling slots must be ventilated vertically
Degree of protection internal components	IP40
Degree of protection terminals	IP20
DIN rail mounting acc. to	IEC 60715
Screw mounting	3 x M4 with mounting clip
Enclosure material	polycarbonate
Flammability class	V-0
Dimensions (W x H x D)	108 x 93 x 110 mm
Documentation number	D00022
Weight	≤ 390 g

**Option "W"**

Ambient temperatures:	
Operating temperature	-40...+70 °C
Classification of climatic conditions acc. to IEC 60721:	
Stationary use (IEC 60721-3-3)	3K5 (condensation and formation of ice possible)
Classification of mechanical conditions acc. to IEC 60721:	
Stationary use (IEC 60721-3-3)	3M7

(\*) = Factory setting



**Bender GmbH & Co. KG**

P.O.Box 1161 • 35301 Gruenberg • Germany  
Londorfer Straße 65 • 35305 Gruenberg • Germany  
Tel.: +49 6401 807-0 • Fax: +49 6401 807-259  
E-mail: [info@bender.de](mailto:info@bender.de) • [www.bender.de](http://www.bender.de)



**BENDERGroup**