

LINETRAXX® RCMA420

AC/DC sensitive residual current monitor for TN and TT systems
(AC, DC and pulsed DC currents)



LINETRAXX® RCMA420

AC/DC sensitive residual current monitor
for TN and TT systems
(AC, DC and pulsed DC currents)



Device features

- AC/DC sensitive residual current monitor Type B acc. to IEC 62020 and IEC/TR 60755
- r.m.s. value measurement (AC+DC)
- Two separately adjustable response values 10...500 mA
- Frequency range 0...2000 Hz
- Start-up delay, response delay and delay on release
- Digital measured value display via LC display
- Measured value memory for operating value
- CT connection monitoring
- LEDs: Power On, Alarm 1, Alarm 2
- Internal/external test/reset button
- Two separate alarm relays (one changeover contact each)
- N/O or N/C operation and fault memory selectable
- Continuous self monitoring
- Multi-functional LC display
- Password protection for device settings
- Sealable transparent cover
- Two-module enclosure (36 mm)
- RoHS compliant
- Push-wire terminal (two terminals per connection)

Approvals



Product description

The AC/DC sensitive residual current monitor RCMA420 is designed for monitoring earthed power supply systems (TN and TT systems) where smooth DC fault currents or residual currents continuously greater than zero may occur. These are in particular loads containing six-pulse rectifiers or one way rectifiers with smoothing, such as converters, battery chargers, construction site equipment with frequency-controlled drives. Currents in single conductors can be monitored too.

The prewarning stage (50...100 % of the set response value $I_{\Delta n2}$) allow to distinguish between prewarning and alarm. Since the values are measured with measuring current transformers, the device is nearly independent of the load current and the nominal voltage of the system.

Applications

- AC/DC sensitive residual current monitoring in earthed two, three or four conductor systems (TN and TT systems)
- Monitoring of variable-speed drives, UPS systems, construction site equipment, printing machines, battery systems, laboratory equipment, wood working machines, MF welding systems, furniture industry, medical electrical equipment, etc.
- AC/DC sensitive current monitoring of, in the normal case, de-energised single conductors (e.g. N and PE conductors)

Function

Once the supply voltage U_S is applied, the start-up delay is activated. Measured values changing during this time do not influence the switching state of the alarm relays.

Residual current measurement takes place via an external measuring current transformer of the W20AB...W60AB series. The currently measured value is shown on the LC display. In this way any changes, for example when circuits are connected to the system, can be recognised easily. If the measured value exceeds the set response values, the response delays $t_{on1/2}$ begin. Once the response delay $t_{on1/2}$ has elapsed, the K1/K2 alarm relays switch and the alarm LEDs AL1/AL2 light up. If the current falls below the release value (response value plus hysteresis), the release delay t_{off} . When t_{off} has elapsed, the alarm relays return to their initial position and the alarm LEDs AL1/AL2 go out. If the fault memory is activated, the alarm relays remain in the alarm state and the LEDs light until the reset button is pressed or until the supply voltage is interrupted. The device function can be tested using the test button. Parameters are assigned to the device via the LCD and the control buttons on the front panel; this function can be password-protected.

Connection monitoring

The function of the device and the CT connections are continuously monitored. In the event of a fault, the alarm relays K1/K2 switch without delay, the alarm LEDs AL1/AL2/ON flash. On removal of the fault, the alarm relays return to their initial position either automatically or by pressing the reset button.



Operating and display elements

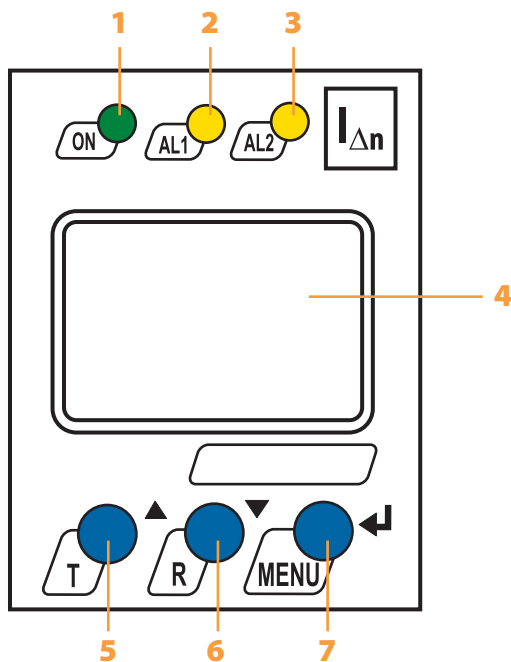

- 1 - Power On LED "ON" (green); lights when supply voltage is applied and flashes in the event of system fault alarm respectively in the event of CT malfunction.
- 2 - Alarm LED "AL1" (yellow), prewarning; lights when the set response value $I_{\Delta n1}$ is exceeded or flashes in the event of system fault alarm respectively in the event of CT malfunction
- 3 - Alarm LED "AL2" (yellow), alarm; lights when the set response value $I_{\Delta n2}$ is exceeded or flashes in the event of system fault alarm respectively in the event of CT malfunction.
- 4 - Multi-functional LC display
- 5 - Test button "T": to call up the self test.
Arrow up button: parameter change, to move up in the menu
- 6 - Reset button "R": to delete saved alarms.
Arrow down button: parameter change, to move down in the menu
- 7 - "MENU" button: to call up the menu system.
Enter button: to confirm parameter change.
"ESC" button: press the button > 1.5 seconds.

Wiring diagram

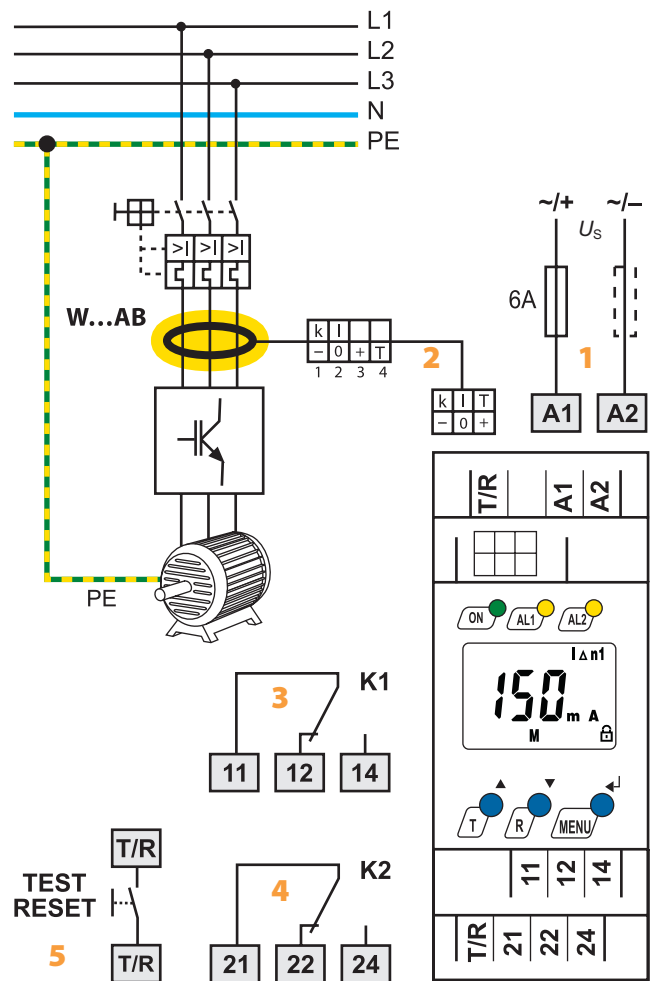

- 1 - Supply voltage U_S see ordering information, 6 A fuse recommended
- 2 - Connector for the external W20AB...W60AB series measuring current transformer
- 3 - Alarm relay "K1": $I_{\Delta n1}$ (prewarning)
- 4 - Alarm relay "K2": alarm $I_{\Delta n2}$ (alarm)
- 5 - Combined test and reset button "T/R"
short-time pressing (< 1.5 s) = RESET
long-time pressing (> 1.5 s) = TEST

Do not route the PE conductor through the measuring current transformer!

Connection of measuring current transformers

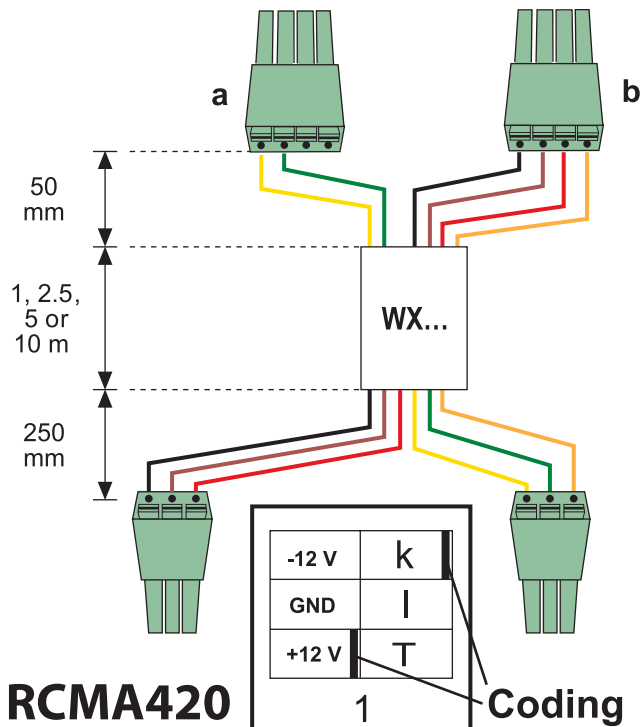
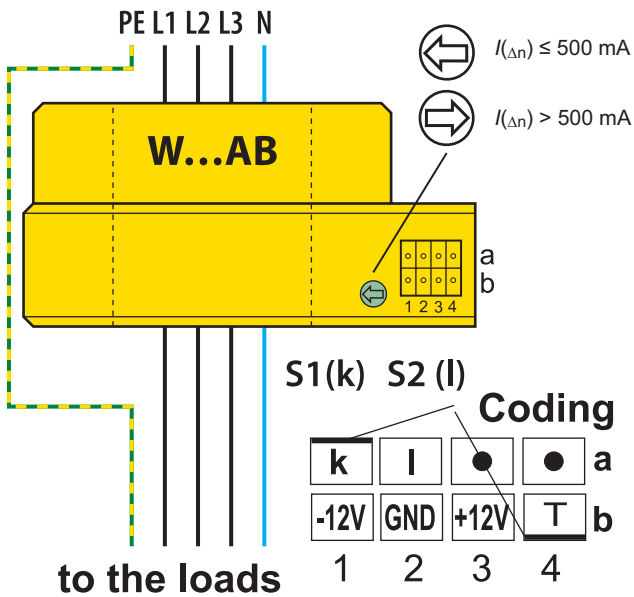

Connection to the RCMA420 residual current monitor using the WX... connecting cable.

Colour coding for WX...: k = yellow, I = green, -12 V = black, GND = brown, +12 V = red, Test (T) = orange

Dimension diagram XM420

Dimensions in mm

Open the front plate cover in direction of arrow!

Screw mounting

Note: The upper mounting clip must be ordered separately (see ordering information).

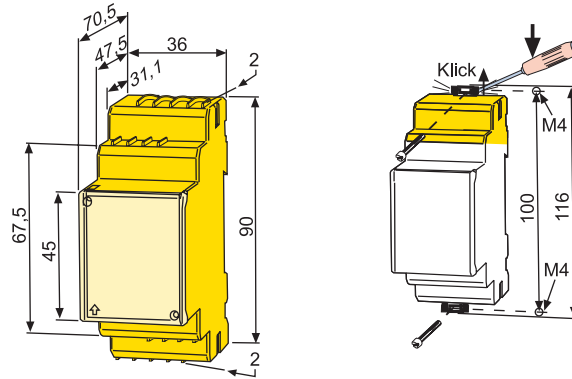

Ordering information

Supply voltage ¹⁾ U _s		Type	Art. No.
DC	AC		
9.6...94 V	16...72 V, 42...460 Hz	RCMA420-D-1	B 7404 3001
70...300 V	70...300 V, 42...460 Hz	RCMA420-D-2	B 7404 3002

Device version with screw terminals on request.

¹⁾ Absolute values

Accessories

Type designation	Art. No.
Mounting clip for screw mounting (1 piece per device)	B 9806 0008

Suitable system components

Type designation	Internal diameter (mm)	Type	Art. No.
Measuring current transformers	∅ 20	W20AB	B 9808 0008
	∅ 35	W35AB	B 9808 0016
	∅ 60	W60AB	B 9808 0026

Type designation	Length/m	Type	Art. No.
Connection cable measuring current transformer	1	WX-100	B 9808 0503
	2,5	WX-250	B 9808 0504
	5	WX-500	B 9808 0505
	10	WX-1000	B 9808 0506

Technical data
Insulation coordination acc. to IEC 60664-1/IEC 60664-3

Rated insulation voltage	250 V
Rated impulse voltage/pollution degree	2.5 kV/3
Protective separation (reinforced insulation) between (A1, A2) - (k, l, T/R) - (11, 12, 14) - (21, 22, 24)	
Voltage tests according to IEC 61010-1	2.21 kV

Supply voltage
RCMA420-D-1:

Supply voltage U_S	AC 16...72 V/DC 9.6...94 V
Frequency range U_S	42...460 Hz

RCMA420-D-2:

Supply voltage U_S	AC/DC 70...300 V
Frequency range U_S	42...460 Hz
Power consumption	≤ 4 VA

Measuring circuit

External measuring current transformer	W20AB, W35AB, W60AB series
Rated insulation voltage (measuring current transformer)	800 V
Operating characteristic acc. to IEC 62020 and IEC/TR 60755	Type B
Rated frequency	0...2000 Hz
Measuring range AC	0...1.5 A
Measuring range DC	0...600 mA
Relative uncertainty	0...-35%
Operating uncertainty	0...35%

Response values

Rated residual operating current $I_{\Delta n1}$ (prewarning, AL1)	50...100 % $\times I_{\Delta n2}$ (50 %)*
Rated residual operating current $I_{\Delta n2}$ (alarm, AL2)	10...500 mA (30 mA)*
Hysteresis	10...25% (15 %)*

Time response

Start-up delay t	0...10 s (0.5 s)*
Response delay t_{on2} (alarm)	0...10 s (0 s)*
Response delay t_{on1} (prewarning)	0...10 s (1 s)*
Delay on release t_{off}	0...99 s (1 s)*
Operating time t_{ae} at $I_{\Delta n} = 1 \times I_{\Delta n1/2}$	≤ 180 ms
Operating time t_{ae} at $I_{\Delta n} = 5 \times I_{\Delta n1/2}$	≤ 30 ms
Response time t_{an}	$t_{an} = t_{ae} + t_{on1/2}$
Recovery time t_b	≤ 300 ms

Cable lengths for measuring current transformers

Connection (see ordering information)	connecting cable WX... 1 m/2.5 m/5 m/10 m
---------------------------------------	---

Displays, memory

Display range, measured value AC	0...1.5 A
Display range, measured value DC	0...600 mA
Error of indication	±17.5 %/± 2 digits
Measured-value memory for alarm value	data record measured values
Password	off/0...999 (off)*
Fault memory alarm relay	on/off (on)*

Inputs/outputs

Cable length for external test/reset button	0...10 m
---	----------

Switching elements

Number of switching elements	2 x 1 changeover contact				
Operating principle	N/C operation or N/O operation (N/C operation)*				
Electrical endurance, number of cycles	10000				
Contact data acc. to IEC 60947-5-1					
Utilisation category	AC-13	AC-14	DC-12	DC-12	DC-12
Rated operational voltage	230 V	230 V	24 V	110 V	220 V
Rated operational current	5 A	3 A	1 A	0.2 A	0.1 A
Minimum contact rating	1 mA at AC/DC ≥ 10 V				

Environment/EMC

EMC	IEC 62020
Operating temperature	-25...+55 °C
Climatic class acc. to IEC 60721	
Stationary use (IEC 60721-3-3)	3K5 (except condensation and formation of ice)
Transport (IEC 60721-3-2)	2K3 (except condensation and formation of ice)
Long-time storage (IEC 60721-3-1)	1K4 (except condensation and formation of ice)
Climatic class acc. to IEC 60721	
Stationary use (IEC 60721-3-3)	3M4
Transport (IEC 60721-3-2)	2M2
Long-time storage (IEC 60721-3-1)	1M3

Connection

Connection type	push-wire terminal
Connection properties	
rigid	0.2...2.5 mm ² (AWG 24...12)
flexible without ferrule	0.2...2.5 mm ² (AWG 24...12)
flexible with ferrule	0.2...1.5 mm ² (AWG 24...16)
Stripping length	10 mm
Opening force	50 N
Test opening, diameter	2.1 mm

Other

Operating mode	continuous operation
Position of normal use	display-oriented
Degree of protection, internal components (IEC 60529)	IP30
Degree of protection, terminals (IEC 60529)	IP30
Enclosure material	polycarbonate
Screw mounting	2 x M4 with mounting clip
DIN rail mounting acc. to	IEC 60715
Flammability class	UL94V-0
Software version	D242 V1.1x
Operating manual	TGH1411
Weight	≤ 150 g

(*) = factory setting



Bender GmbH & Co. KG

P.O. Box 1161 • 35301 Grünberg • Germany
Londorfer Straße 65 • 35305 Grünberg • Germany
Tel.: +49 6401 807-0 • Fax: +49 6401 807-259
E-Mail: info@bender-de.com • www.bender-de.com

BENDER Group