

# Power Quality and Energy Measurement PEM735

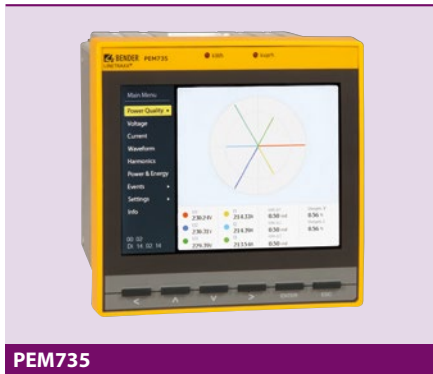

# Power Quality and Energy Measurement

## PEM735

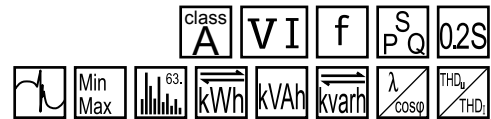

PEM735

### Product description

The digital universal measuring device PEM735 is suited for measuring and displaying electrical quantities of electricity networks. The device measures currents and voltages, energy consumption and power, and displays the individual current/voltage harmonics for assessment of the power quality in accordance with DIN EN 50160. The accuracy of active energy measurements corresponds to class 0.2 S in accordance with DIN EN 62053-22 (VDE 0418 part 3-22). The current inputs are connected via external .../1 A or .../5 A measuring current transformers.

### Typical application

- Continuous monitoring of the voltage quality in accordance with DIN EN 50160
- Collection of relevant data for energy management systems
- High-resolution waveform recording allows analysis of power quality phenomena

### Device features

- Class A power analyser, certified according to DIN EN 61000-4-30
- Monitoring the quality of the voltage in accordance with DIN EN 50160
- Accuracy class according to IEC 62053-22: 0.2 S
- TFT colour display (640x480) 5.7"
- Modbus RTU and Modbus TCP
- 4 current inputs
- 5 voltage inputs
- 1 GB internal memory
- Panel mounting 144x144
- Integrated web server
- Flicker measurement
- Detection and recording of transients (40  $\mu$ s)
- Sampling rate: 512 samples/cycle
- Freely configurable recorders for waveform, consumption and long-term recording

### Description of function

- Sampling rate of the measuring channels: 25.6 kHz
- Calculation of the total harmonic distortion THDU/THDI: harmonics up to the 63rd harmonic
- Individual current/voltage harmonics
- Password protection
- History memory for minimum and maximum values of current, voltage, energy, power rating etc. for each month.
- Inputs and outputs:
  - 6 digital outputs, 8 digital inputs (1 kHz sampling rate)
  - 24 adjustable parameter setpoints
  - System protocol: 1024 events, setup changes, setpoint alarming, DI status changes, DO switching operations
- Communication:
  - Galvanically isolated RS-485 interface (1.200 to 19.200 bit/s)
  - Modbus RTU protocol
  - Modbus TCP (10/100 MBit/s)

### Standards

The universal measuring device for Power Quality and Energy Measurement/PEM735 was developed in accordance with the following standards: IEC 62053-22(VDE 0418 Part 3-22), DIN EN 61557-12 (VDE 0413-12), DIN EN 50160, DIN EN 61000-4-30 (VDE 0847-4-30), DIN EN 61000-4-7 (VDE 0847-4-7), DIN EN 61000-4-15 (VDE 0847-4-15)

Operating elements

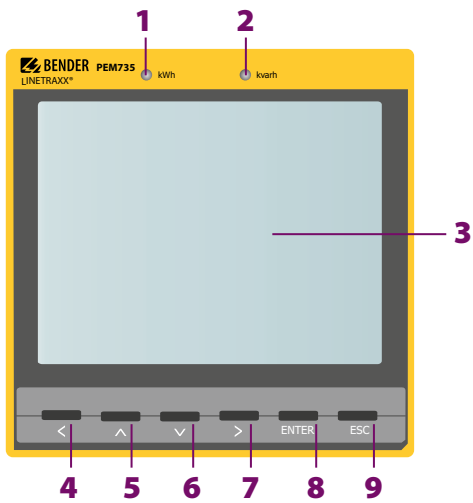

- 1 - Pulse LED: kWh
- 2 - Pulse LED: kvarh
- 3 - Display
- 4 - "<" button: Selection (in the menu)
- 5 - "^" button: Up (in the menu)
- 6 - "v" button: Down (in the menu)
- 7 - ">" button: Selection (in the menu)
- 8 - "ENTER" button: OK
- 9 - "ESC" button:

Example for system set-up

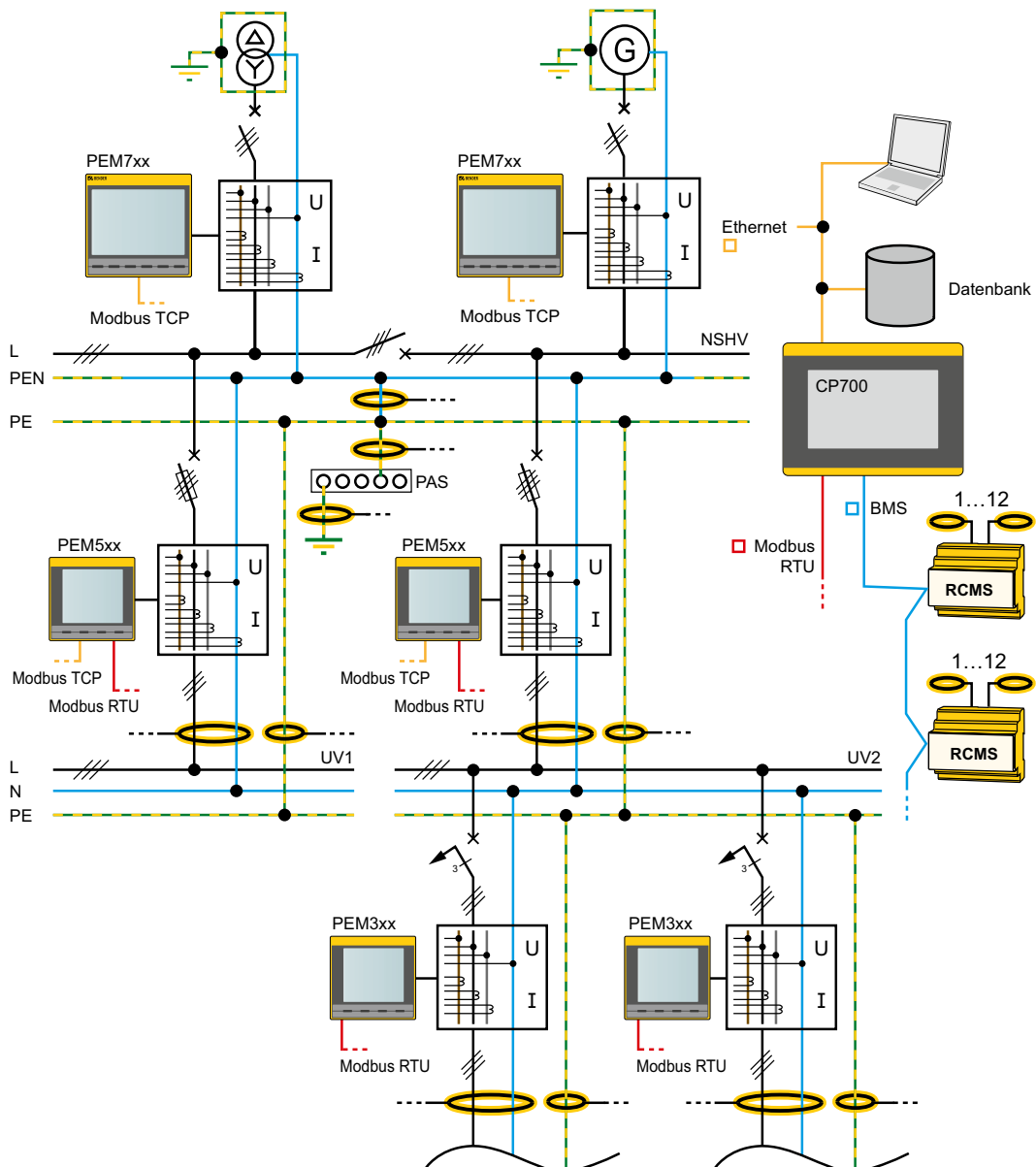

**Wiring diagram**

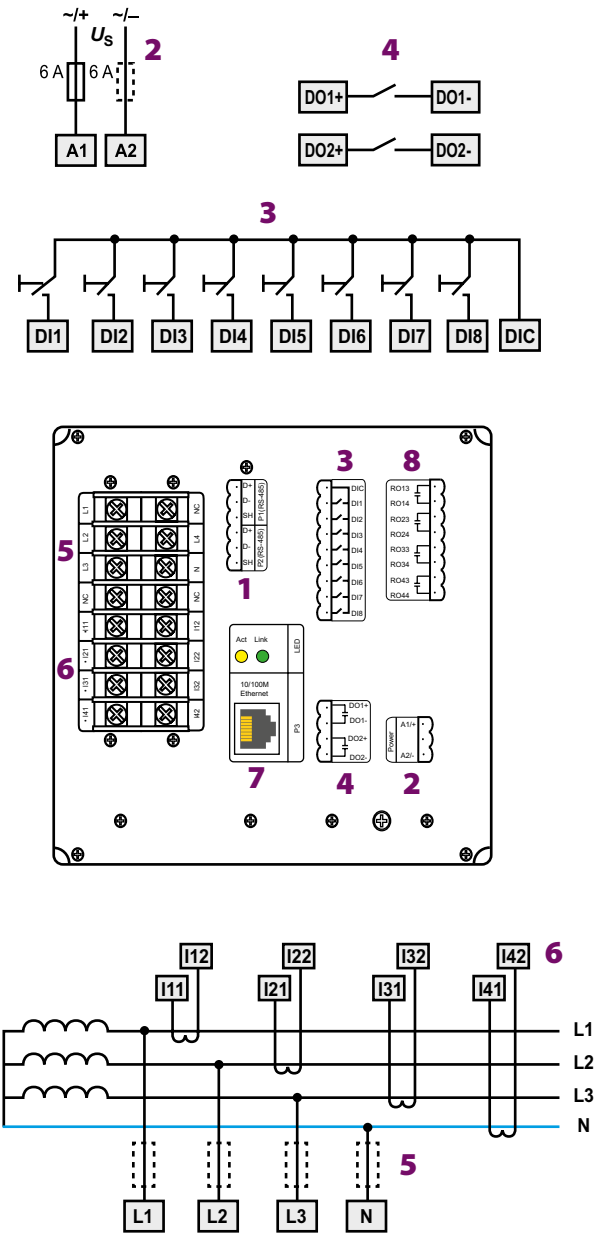

- 1 - Connection RS-485 bus
- 2 - Supply voltage. Power protection by a 6 A fuse, quick response. If being supplied from an IT system, both lines have to be protected by a fuse.
- 3 - Digital inputs
- 4 - Digital outputs (N/O contacts)
- 5 - Measuring voltage inputs:  
The measuring leads should be protected with appropriate fuses
- 6 - Connection to the system to be monitored
- 7 - Connection Ethernet
- 8 - Relay output

**Connection diagram voltage inputs**

**Three-phase 4-wire system (TN, TT, IT systems)**

The PEM can be used in three-phase 4-wire systems, independent of the type of distribution system (TN, TT, IT system).

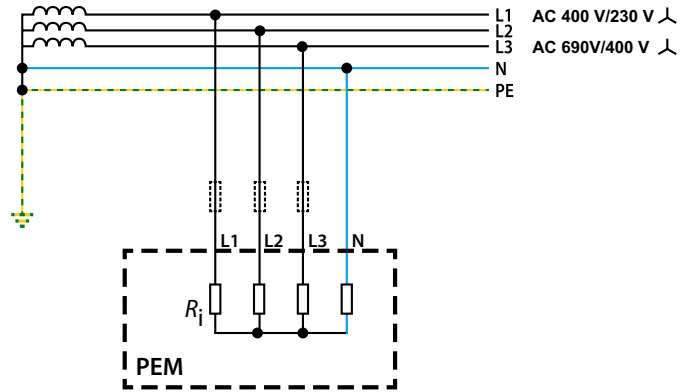

**Three-phase 3-wire system**

The PEM can be used in three-phase 3-wire systems.

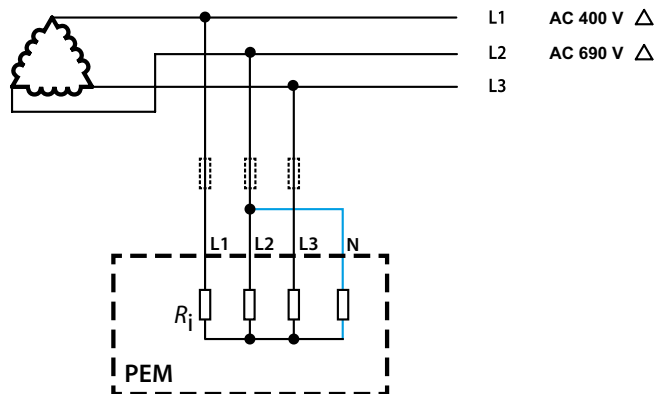

**Connection via voltage transformers**

The coupling via measuring current transformers allows the use of the measuring device in medium and high voltage systems. The transformation ration can be adjusted in the PEM735.

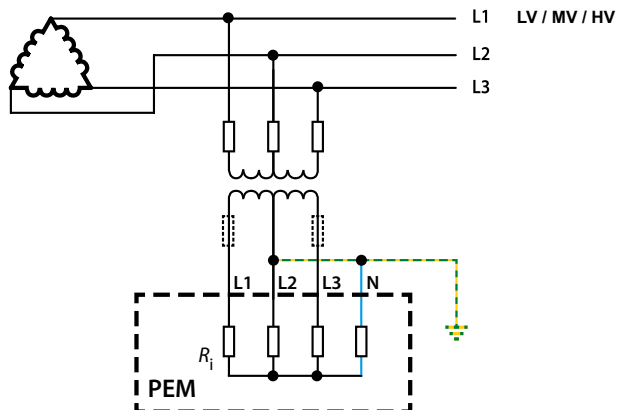

**Technical data**
**Insulation co-ordination**
**Measuring circuit**

Rated insulation voltage	600 V
Overvoltage category	III
Pollution degree	2

**Supply circuit**

Rated insulation voltage	300 V
Overvoltage category	II
Pollution degree	2

**Supply voltage**

Rated supply voltage $U_S$	95...250 V
Frequency range of $U_S$	DC, 44...440 Hz
Power consumption	≤ 14 VA

**Measuring circuit**
**Measuring voltage inputs**

$U_{L1-N, L2-N, L3-N}$	400 V
$U_{L1-L2, L2-L3, L3-L1}$	690 V
Measuring range	10...120 % $U_n$
CT transformation ratio	
Primary	1...1,000,000 V
Secondary	100...690 V ULL (1...3)
Secondary	1...400 V (U4)
Internal resistance (L-N)	> 6 M $\Omega$

**Measuring current inputs**

External measuring current transformer	should at least comply with accuracy class 0.2 S
Burden	n.A., internal current transformers
Measuring range	0.1...120 % $I_N$
Transducer ratio, secondary	1...5 A
Transducer ratio, primary	1...30000 A

**Accuracies (of measured value/of full scale value)**

Phase voltage $U_{L1-N}, U_{L2-N}, U_{L3-N}$	± 0.1 % of the measured value.
Current	± 0.1 % of measured value + 0.05 % of full scale value.
Neutral current $I_4$	0.5 % v. S.
Frequency	± 0.005 Hz
Phase position	± 1 °
Active energy measurement acc. to	DIN EN 62053-22 (VDE 0418 Part 3-22)
R.m.s. voltage measurements acc. to	DIN EN 61557-12 (VDE 0413-12), chapter 4.7.6
R.m.s. phase current measurements acc. to	DIN EN 61557-12 (VDE 0413-12), chapter 4.7.5
Frequency measurements acc. to	DIN EN 61557-12 (VDE 0413-12), chapter. 4.7.4
Measurement of the harmonics acc. to	DIN EN 61000-4-7 class A

**Interface**

Interface/protocol	2 x RS-485, Modbus RTU
Baud rate	1.2...19.2 kbits/s
Cable length	0...1200 m
Shielded cable ((shield connected to PE on one side)	recommended: J-Y(St)Y min. 2x0.8

Interface	Ethernet
Protocol	Modbus TCP
Baud rate	100 MBit/s

**Switching elements**

2 electronic outputs (DO)	max. 80 V
	$I_{max}$ 50 mA
Outputs (RO)	4 x N/O contacts
Operating principle	N/O operation
Rated operational voltage	AC 230 V DC 24 V AC 110 V DC 12 V
Rated operational current	5 A 5 A 6 A 5 A
Minimum contact rating	1 mA at AC/DC ≥ 10 V
Inputs	8 electrically separated digital inputs
$I_{min}$	2.4 mA
$U_{DI}$	DC 24 V

**Environment/EMC**

EMC	IEC 61326-1
Operating temperature	-25...+55 °C
Climatic class acc. to DIN EN 60721	
stationary use	3K5
Classification of mechanical conditions acc. to IEC 60721	
stationary use	3M4
Height	to 4000 m

**Connection**

Connection	screw-type terminals
------------	----------------------

**Other**

Degree of protection, installation	IP20
Degree of protection, front	IP52
Documentation number	D00084
Weight	≤ 2000 g

## Ordering information

Nominal system voltage	Current input	Type	Art. No.
3(N)AC			
100...690 V	5 A	PEM735	B 9310 0735

## Suitable system components

Measuring current transformer					
Primary current	Accuracy	Secondary current	Type	Design	Art. No.
60	1	5	WL605 KL.1	CTB41	B 9808 6001
		1	WL60-1 KL.1	CTB41	B 9808 6002
75	1	5	WL755 KL.1	CTB41	B 9808 6003
		1	WL75-1 KL.1	CTB41	B 9808 6004
125	0.5	5	WL1255 KL.0,5	CTB41	B 9808 6005
		1	WL125-1 KL.0,5	CTB41	B 9808 6006
	1	5	WL125-5 KL.1	CTB41	B 9808 6007
		1	WL125-1 KL.1	CTB41	B 9808 6008
150	0.5	5	WL1505 KL.0,5	CTB41	B 9808 6009
		1	WL150-1 KL.0,5	CTB41	B 9808 6010
	1	5	WL150-5 KL.1	CTB41	B 9808 6011
		1	WL150-1 KL.1	CTB41	B 9808 6012
200	0.5	5	WL2005 KL.0,5	CTB41	B 9808 6013
		1	WL200-1 KL.0,5	CTB41	B 9808 6014
	1	5	WL200-5 KL.1	CTB41	B 9808 6015
		1	WL200-1 KL.1	CTB41	B 9808 6016
250	0.5	5	WL2505 KL.0,5	CTB41	B 9808 6017
		1	WL250-1 KL.0,5	CTB41	B 9808 6018
	1	5	WL250-5 KL.1	CTB41	B 9808 6019
		1	WL250-1 KL.1	CTB41	B 9808 6020
300	0.5	5	WL3005 KL.0,5	CTB41	B 9808 6021
		1	WL300-1 KL.0,5	CTB41	B 9808 6022
	1	5	WL300-5 KL.1	CTB41	B 9808 6023
		1	WL300-1 KL.1	CTB41	B 9808 6024

Measuring current transformer					
Primary current	Accuracy	Secondary current	Type	Design	Art. No.
400	0.5	1	WL400-1 KL.0,5	CTB41	B 9808 6025
	1	5	WL400-5 KL.1	CTB41	B 9808 6026
	0.5	5	WL400-5 KL.0,5	CTB41	B 9808 6027
	1	1	WL400-1 KL.1	CTB41	B 9808 6028
500	1	5	WL500-5 KL.1	CTB41	B 9808 6029
	0.5	5	WL500-5 KL.0,5	CTB41	B 9808 6031
	1	1	WL500-1 KL.1	CTB41	B 9808 6032
	0.5	1	WL500-1 KL.0,5	CTB41	B 9808 6033
600	1	5	WL600-5 KL.1	CTB51	B 9808 6034
	0.5	5	WL600-5 KL.0,5	CTB51	B 9808 6035
	1	1	WL600-1 KL.1	CTB51	B 9808 6036
	0.5	1	WL600-1 KL.0,5	CTB51	B 9808 6037
800	1	5	WL800-5 KL.1	CTB51	B 9808 6038
	0.5	5	WL800-5 KL.0,5	CTB51	B 9808 6039
	1	1	WL800-1 KL.1	CTB51	B 9808 6040
	0.5	1	WL800-1 KL.0,5	CTB51	B 9808 6041
1000	1	5	WL1000-5 KL.1	CTB51	B 9808 6042
	0.5	5	WL1000-5 KL.0,5	CTB51	B 9808 6043
	1	1	WL1000-1 KL.1	CTB51	B 9808 6044
	0.5	1	WL1000-1 KL.0,5	CTB51	B 9808 6045
50	3F55	1	WLS501 KL.3F55	KBR18	B 9808 6046
100	3F55	1	WLS1001 KL.3F55	KBR18	B 9808 6047
150	3F55	1	WLS1501 KL.3F55	KBR18	B 9808 6048
250	3F55	1	WLS2501 KL.3F55	KBR32	B 9808 6049
500	3F55	1	WLS5001 KL.1F55	KBR32	B 9808 6050

**Dimension diagram**

Dimensions in mm

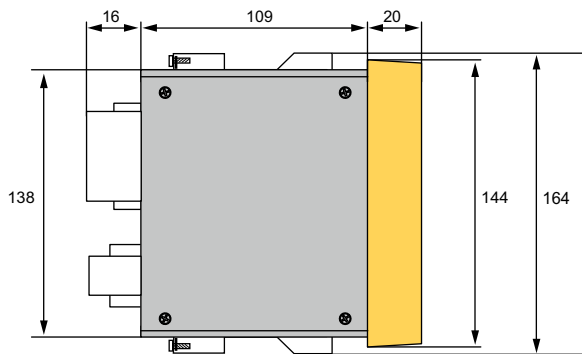
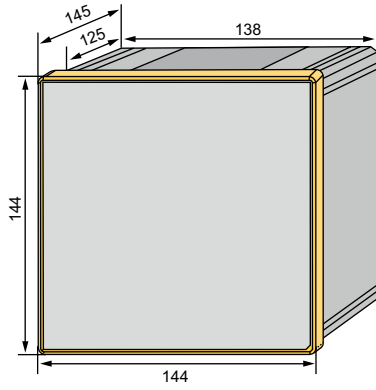

**Panel cut-out**

Dimensions in mm

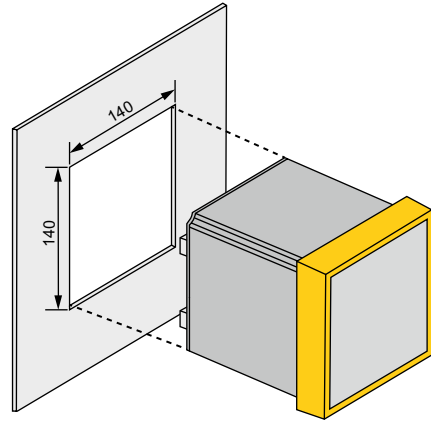



**Bender GmbH & Co. KG**

P.O.Box 1161 • 35301 Grünberg • Germany  
Londorfer Straße 65 • 35305 Grünberg • Germany  
Tel.: +49 6401 807-0 • Fax: +49 6401 807-259  
E mail: [info@bender.de](mailto:info@bender.de) • [www.bender.de](http://www.bender.de)



**BENDERGroup**