

Power Quality and Energy Measurement PEM533



Power Quality and Energy Measurement

PEM533



PEM533

Device features

- Accuracy class according to IEC 62053-22: 0.5 S
- Measured quantities
 - (Phase) voltages U_{L1}, U_{L2}, U_{L3} in V
 - Line-to-line voltages $U_{L1L2}, U_{L2L3}, U_{L3L1}$ in V
 - Phase currents I_1, I_2, I_3 in A
 - Neutral current (calculated) I_4 in A
 - Frequency f in Hz
 - Phase angle for U and I in $^\circ$
 - Power per phase conductor S in kVA, P in kW, Q in kvar
 - Total power S in kVA, P in kW, Q in kvar
 - Displacement factor $\cos(\varphi)$
 - Power factor λ
 - Active and reactive energy import in kWh, kvarh
 - Active and reactive energy export in kWh, kvarh
 - Voltage unbalance in %
 - Current unbalance in %
 - Total harmonic distortion (THD) for U and I
 - k-Factor for I
- Programmable setpoint monitoring
- LED pulse outputs for active and reactive energy
- Modbus-RTU communication via RS-485
- 2 digital outputs
- Demands of energy and current for particular time frames
- Peak demands with timestamps
- Individual current/voltage harmonics up to the 31st harmonic
- Minimum and maximum values

Product description

The digital universal measuring device PEM533 is suited for measuring and displaying electrical quantities of electricity networks. The PEM575 is able to perform current, voltage, energy consumption and performance measurements as well as displaying individual current/voltage harmonics for assessment of the power quality. The accuracy of active energy measurements corresponds to class 0.5 S in accordance with the requirements of DIN EN 62053-22 (VDE 0418 Part 3-22). The current inputs are connected via external .../1 A or .../5 A measuring current transformers.

Typical application

- As a compact device for front panel mounting, the PEM533 is a replacement for analogue indicating instruments
- Typical application in low and medium-voltage networks (via measuring voltage transformer)
- Power quality monitoring
- Collection of relevant data for energy management systems
- Cost allocation of energy consumption

Description of function

- Sampling rate of the measuring channels: 3.2 kHz
- Calculation of the total harmonic distortion THD_U/THD_I: up to the 31st harmonic
- Individual current/voltage harmonics
- Password protection
- Clamp mechanism, no tools required
- History memory for minimum and maximum values of current, voltage, energy, power rating etc. for each month
- Inputs and outputs:
 - 2 digital outputs, 6 digital inputs
 - 9 user-programmable setpoints (response values, response delay 0...9999 seconds)
 - System protocol: 64 events, setup changes, setpoint alarming, DI status changes, DO switching operations
- Communication:
 - Galvanically isolated RS-485 interface (1,200 bis 19,200 bit/s)
 - Modbus RTU protocol

Standards

The universal measuring device for Power Quality and Energy Measurement/PEM533 was developed in accordance with the following standards: DIN EN 62053-22 (VDE 0418 Part 3-22), DIN EN 61557-12 (VDE 0413-12)

Features

	PEM533
RS-485	■
Digital inputs	6
Digital outputs	2
Sampling rate	3.2 kHz
THD calculation and harmonics	31.

Operating elements

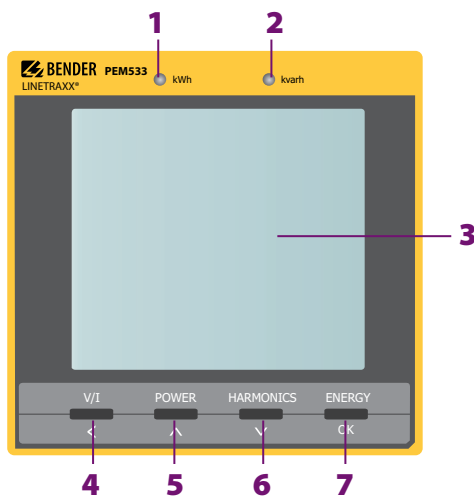

- 1 - Pulse LED: kWh
- 2 - Pulse LED: kvarh
- 3 - Display
- 4 - "V/I" button: Selection (in the menu)
- 5 - "POWER" button: Up (in the menu)
- 6 - "HARMONICS" button: Down (in the menu)
- 7 - "ENERGY" button: OK (in the menu)

Press the "ENERGY" button > 1.5 s to enter/leave the Setup menu.

Example for system set-up

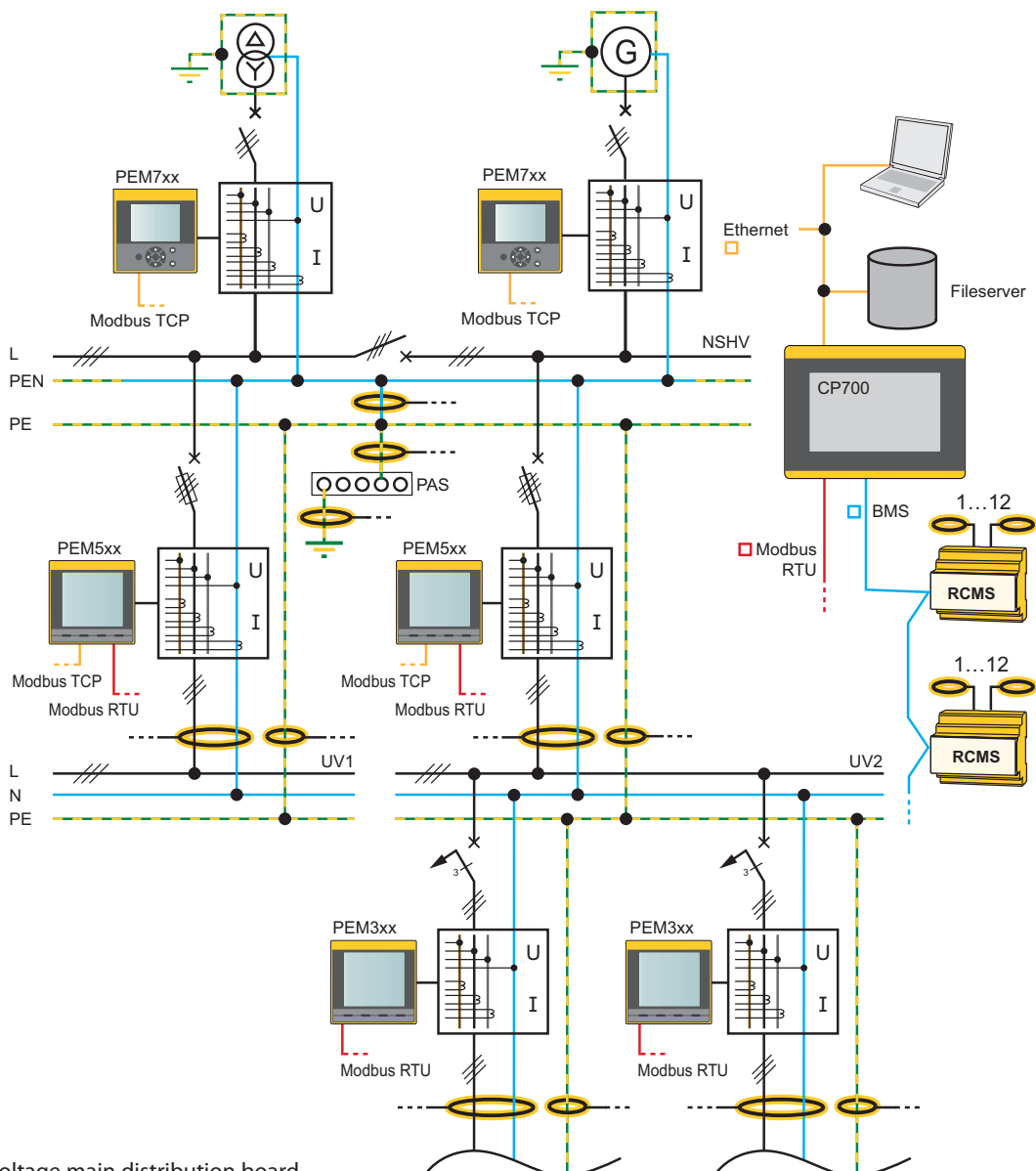

NSHV = Low-voltage main distribution board

Wiring diagram

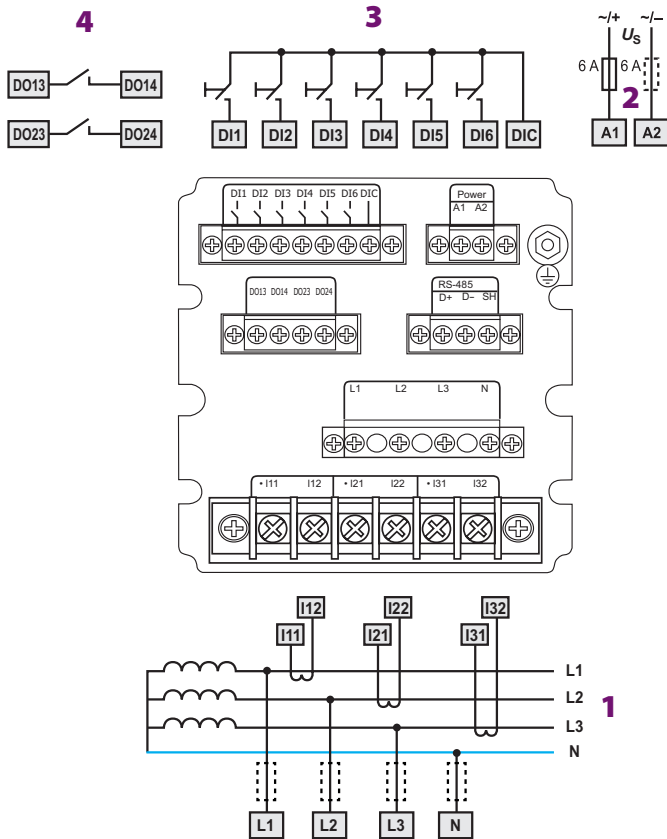

- 1** - Connection to the system to be monitored:
The measuring leads should be protected with appropriate fuses.
- 2** - Supply voltage. Line protection by a fast-acting 6-A fuse. If being supplied from an IT system, both lines have to be protected by a fuse.
- 3** - Digital inputs
- 4** - Digital outputs (N/O contacts)

Connection diagram voltage inputs

Three-phase 4-wire system (TN, TT, IT systems)

The PEM can be used in three-phase 4-wire systems, independent of the type of distribution system (TN, TT, IT system).

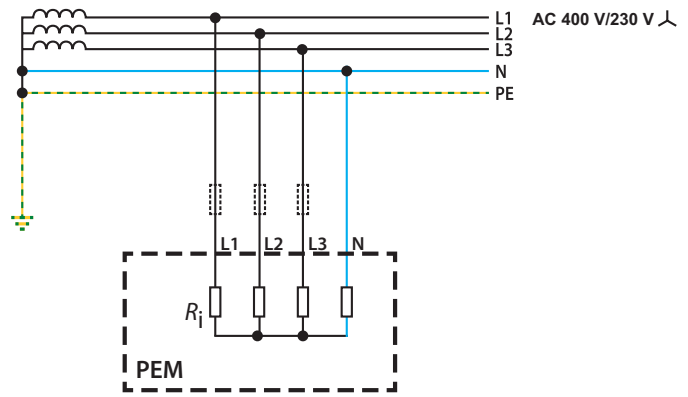

Three-phase 3-wire system

The PEM can be used in three-phase 3-wire systems. The line-to-line voltage must not exceed AC 400 V.

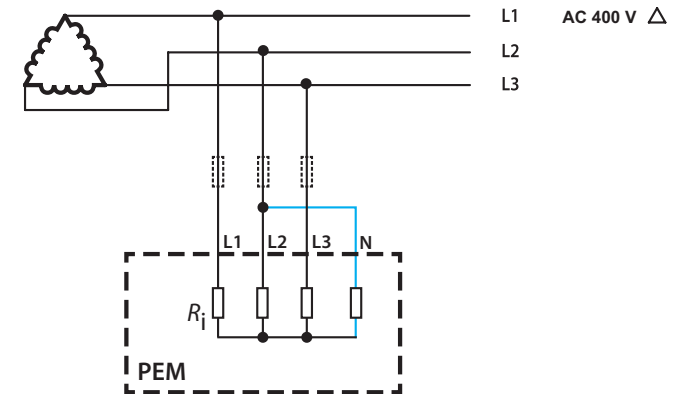

Connection via voltage transformers

The coupling via measuring voltage transformers allows the use of a measuring device in medium and high voltage systems. The transformation ratio in PEM533 can be adjusted (1...2200).

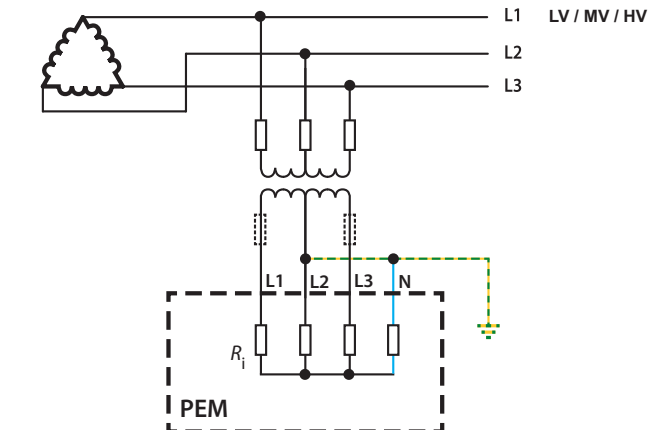

Technical data
Insulation co-ordination
Measuring circuit

Rated insulation voltage	300 V
Overvoltage category	III
Pollution degree	2

Supply circuit

Rated insulation voltage	300 V
Overvoltage category	II
Pollution degree	2

Supply voltage

Rated supply voltage U_S	95...250 V
Frequency range of U_S	DC, 44...440 Hz
Power consumption	≤ 4 VA

Measuring circuit
Measuring voltage inputs

$U_{L1-N, L2-N, L3-N}$	230 V
$U_{L1-L2, L2-L3, L3-L1}$	400 V
Measuring range	10... 120 % U_N
Rated frequency	45...65 Hz
Internal resistance (L-N)	> 500 k Ω

Measuring current inputs

External measuring current transformer

should at least comply with accuracy class 0.5 S

Burden	n.A., internal current transformers
Measuring range	0.1... 120 % I_N
PEM533/PEM533-455	
I_N	5 A
Measuring current transformer ratio	1...6000
PEM533-251/PEM533-451	
I_N	1 A
Measuring current transformer ratio	1...30000

Accuracies (of measured value/of full scale value)

Phase voltage $U_{L1-N}, U_{L2-N}, U_{L3-N}$	± 0.2 % of measured value
Current	± 0.2 % of measured value + 0.05 % of full scale value
Neutral current I_4	1 % of full scale value
Frequency	± 0,02 Hz
Phase position	± 1°
Active energy measurement according to	DIN EN 62053-22 (VDE 0418 Part 3-22)
r.m.s. voltage measurement according to	DIN EN 61557-12 (VDE 0413-12), chapter 4.7.6
r.m.s. phase current measurement according to	DIN 61557-12 (VDE 0413-12), chapter 4.7.5
Frequency measurement according to	DIN EN 61557-12 (VDE 0413-12), chapter 4.7.4

Interface

Interface/protocol	RS-485/Modbus/RTU
Baud rate	1.2...19.2 kbits/s
Cable length	0...1200 m
Shielded cable (shield connected to terminal SH on one side)	recommended: J-Y(St)Y min. 2 x 0.8

Switching elements

Outputs	2 N/O contacts
Operating principle	N/O operation
Rated operational voltage	AC 230 V DC 24 V AC 110 V DC 12 V
Rated operational current	5 A 5 A 6 A 5 A
Minimum contact rating	1 mA at AC/DC ≥ 10 V
Inputs	6 electrically separated digital inputs
I_{min}	2.4 mA
U_{DI}	DC 24 V

Environment/EMC

EMC	DIN EN 61326-1
Operating temperature	-25...+55 °C
Climatic class acc. to DIN EN 60721	
Stationary use	3K5
Classification of mechanical conditions acc. to DIN EN 60721	
Stationary use	3M4

Connection

Connection	screw-type terminals
------------	----------------------

Other

Degree of protection, front	IP54
Operating manual	TGH1476
Weight	≤ 1100 g

Ordering information

Interface	Nominal system voltage	Current input	Type	Art. No.
RS-485	3(N)AC 400/230 V	5 A	PEM533	B 9310 0533
		1 A	PEM533-251	B 9310 0534
	3(N)AC 690/400 V	5 A	PEM533-455	B 9310 0535
		1 A	PEM533-451	B 9310 0536

Dimension diagram

Dimensions in mm

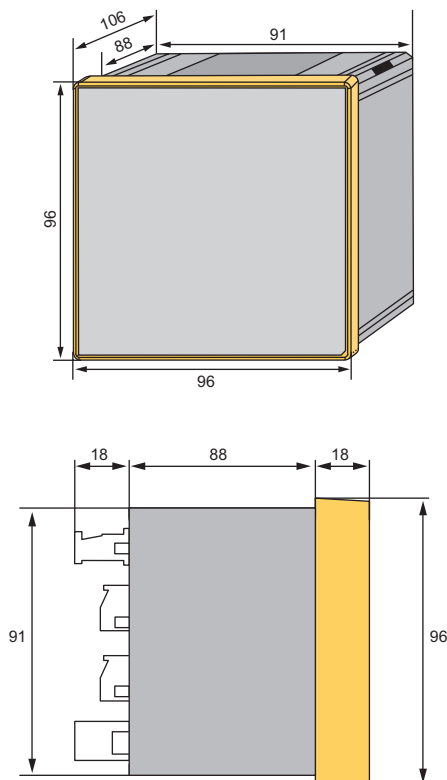

Panel cut-out

Dimensions in mm

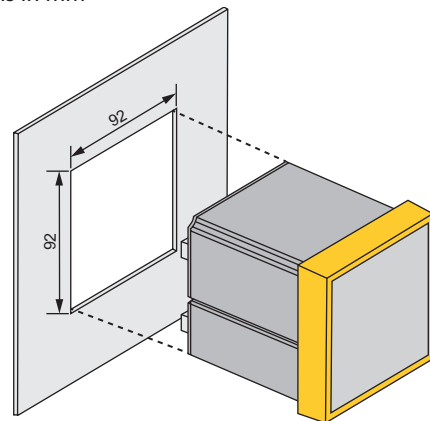

Bender GmbH & Co. KG

P.O.Box 1161 • 35301 Gruenberg • Germany
 Londorfer Straße 65 • 35305 Gruenberg • Germany
 Tel.: +49 6401 807-0 • Fax: +49 6401 807-259
 E-mail: info@bender-de.com • www.bender-de.com