



Tables of Contents	Page	Features
Application	1	- 16 signals
Features	1	- One housing option
Important Safety Information!	2	- Front panel with keypad, LED-Backlight and sound
Note to this Guide	2	- Easy to replace alarm-text on printable transparency stripes
Further Information	2	- Factory default configuration (optional programming adapter available)
General Functions	3	- DC and AC power supply possible
Annunciator Sequences - ISA 18.1	3	- Wide range power supplies from 24 V DC up to 230 V AC
Plan of Terminal Connections	4	- 2 relay outputs for collective annunciation
Wiring for the Alarm Annunciator	5	- Plugs with spring-cage connector
ISA 18.1 in Detail	6	- Isolated power supplies and signals
Technical Data	7	
International Standards	7	
Connection Technology	7	
Control and Monitoring Elements	8	
Dimension Drawing	9	
Labeling of the Messages	10	
Panel Mounting	10	
Spacing of the modules	10	
Spare Parts	10	

Application

The *ME 3011E Digital Alarm Annunciator* module is for registering signals, alarms, states and events from electrical systems.

The gathered information can be provided locally via LED's and horn.

Important Safety Information!

The device description must be read and understood prior to any installation or operation. Installation, wiring, commissioning and maintenance of the *Digital Alarm Annunciator* module should only be carried by qualified personnel, authorized by the plant owner and under strict compliance with the relevant standards and safety regulations. Any installation works should only be carried with the system disconnected from the mains supply. Please don't hesitate to contact us if you have questions or need any further information.

Note to this Guide

This guide describes the system ME 3011E. Depending on the wide range of hardware-configuration, there is a nearly endless amount of different systems. This document only describes a few of the possibilities.

Further Information

To find on www.bilfinger.mauell.com.

Information and data contained in this documentation may be changed without prior notice. The company names, other names and data used in examples are fictitious. This documentation or parts hereof may not be used for duplication or translation regardless of the purpose or the method, whether electronically or mechanically, without express prior written permission of Bilfinger Mauell GmbH.

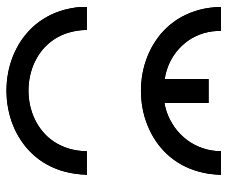

The product described in this brochure is intended for industrial use and meets the requirements laid down by the EU directive 2004/108/EC.

® 2014 Bilfinger Mauell GmbH and ME 3011E *Digital Alarm Annunciator* are names of Bilfinger Mauell GmbH products. Other trade names and product names are labels or registered brands of their owner.

General Functions

Sound Signal

The Digital Alarm Annunciator has a horn/buzzer to generate different signaling. Potential-free connectors are available on the rear panel for connecting an external horn.

Alarm Groups

The alarm group function (annunciation collective) is used to combine inputs for a purposeful monitoring.

A certain alarm group can have its own light indication and sound signaling.

The *Digital Alarm Annunciator* has 2 relays, which are activated if an alarm occurs in one of the 2 alarm groups.

Input Temporization

Every input has a signal delay filter which enables a tripping time from 5 ms up to 600 ms in 2.5 ms steps (factory pre-set).

LED Signaling

Light signaling has two flashing frequencies

Normal flashing: circa 1.2 Hz

Slow flashing: circa 0.4 Hz

Annunciator Sequences - ISA 18.1

The Instrumentation, Systems, and Automation Society (ISA) is a global, non-profit organization for setting the standards for automation.

The purpose of the ISA 18.1 standard is to establish uniform annunciator terminology, sequence designations, and sequence presentation and to assist in the preparation of annunciator specifications and documentation.

This Standard is intended to improve communications among those that specify, distribute, manufacture, or use annunciators.

The Digital Alarm Annunciator can be configured for 16 signaling sequences.

The most important are the following 7:

ISA-RP 18.1/(ISA-S18.1) see page 6-12

ISA 1/(A), ISA 1A/(A-5),

ISA 1B/(A-4), ISA 2A/(R-8),

ISA 2C/(M) default

ISA 4A/(F1A), ISA 4AR/(F1M)

etc.

Other sequences can be implemented on request.

ME 3011E / Alarm Indication / Quick Reference Guide

Plan of Terminal Connections

Clamp	Pin	Title	Meaning	
X1	1-8	I1-I8	Alarm Inputs 1-8	
	9	M	common root (GND)	
X2	1-8	I9-I16	Alarm Inputs 9-16	
	9	M	common root (GND)	
X3	1	L1+	Power Supply Inputs 24-60V DC or 110-230V AC/DC	
	2	M		GND
	3	RL4	Programmable relay outputs (Annunciation collective, Horn) Relays 1	
	4	RL5		Relays 2
	5	L+		common potential for RL4 and RL5
X4	1	HA	Inputs for remote Pushbuttons Horn Acknowledge	
	2	LA	Lamp Acknowledge	
	3	RE	Lamp Reset	
	4	M	common root is (GND)	
B1	1-4	PRG PIC	Confware Upload	
B2	1-4	ConfI	Configuration plug (factory use)	
		PE	Protective Earth. Have to be connected with low-resistance!	

Wiring for the Alarm Annunciator

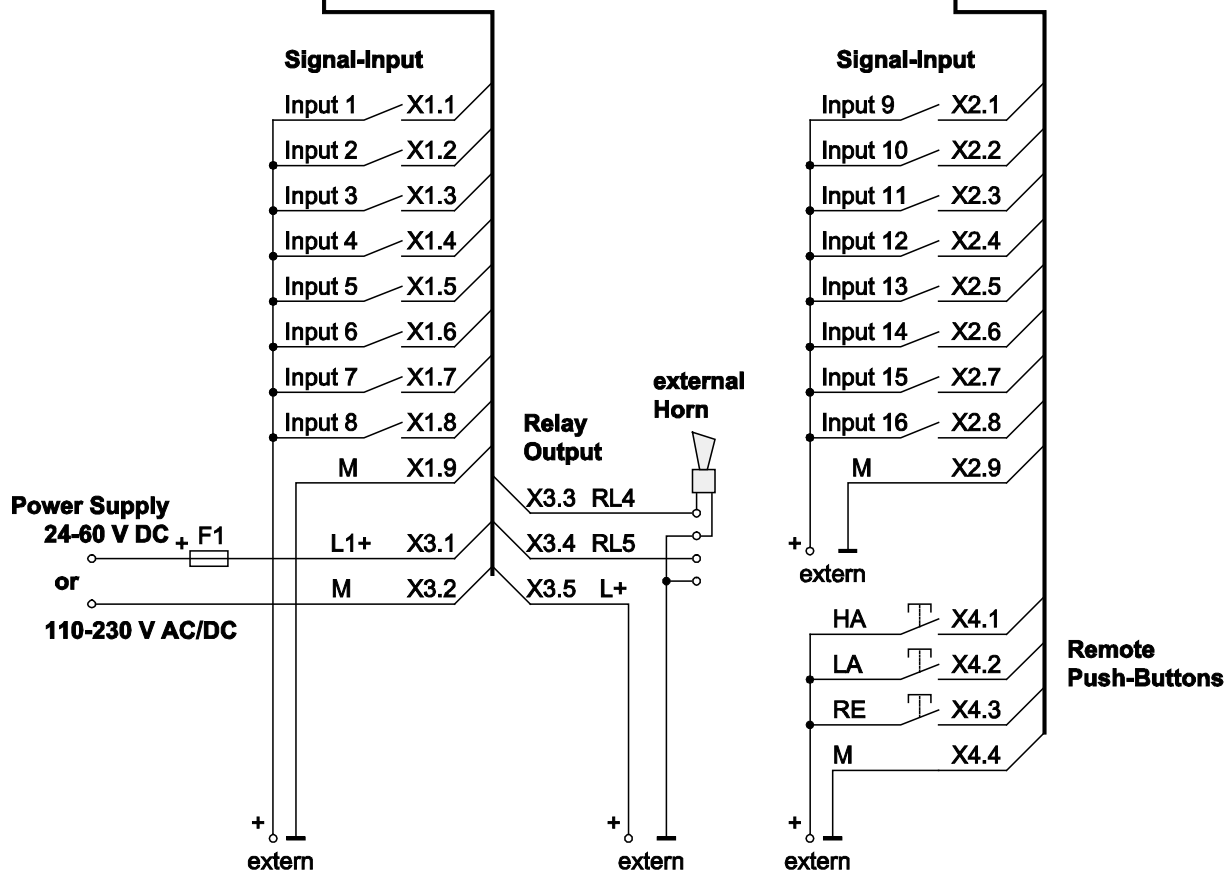
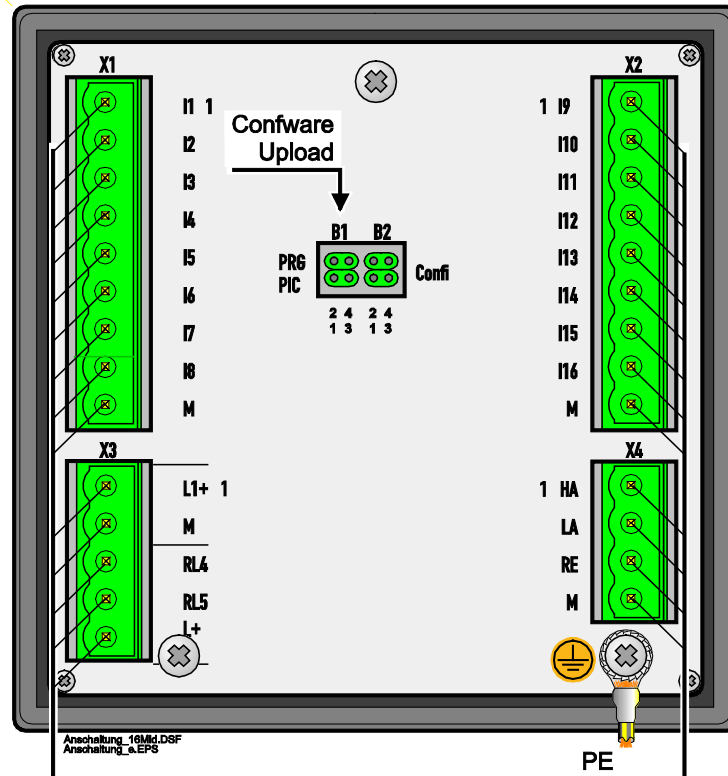

ME 3011E / Alarm Indication / Quick Reference Guide

ISA 18.1 in Detail

Alarm Sequences

ISA	Normal	Alarm	Acknowledge		Back to Normal	Back to Normal before Acknowl.	Acknowledge		Reset light
			Sound	Light			Sound	Light	
ISA 1									
ISA 1A									
ISA 1B									
ISA 2A									
ISA 2C (default)									

Sequence primary Signal (1st Event)

ISA	Normal	Alarm		Acknowledge		Back to Normal		Back to Normal before Acknowledge		Acknowledge		Reset light
		First	Subseq.	First	Subseq.	First	Subseq.	First	Subseq.	First	Subseq.	
ISA 4A												
ISA 4R												

Legend

- Horn Off
- Horn On
- LED Off
- LED On – No Flashing
- LED Normal Flashing
- LED Slow Flashing

Technical Data

Power Supply

Wattage: ca 5 W

standard

X3.1-2: 24-60 V DC $\pm 20\%$

optional AC/DC

X3.1-2: 110-230 V AC/DC $-20/+10\%$

Inputs

Alarm: 16

DC $\pm 20\%$: 24, 48, 60 V

DC $-20/+10\%$: 110, 220 V

Current: typically 2 mA

Filter: 5 ms up to 600 ms

Remote-Inputs: 3 x 24 V DC

Functions: HA, LA, RE

Outputs

Horn/Buzzer: 90 dB / 10 cm, 4 kHz

RL4-5
2 Relay contacts
programmable for,
external horn and
alarm groups

Capacity of RLFL1-2 and RL3-5

Relay contacts: 30 V DC-1.0 A ohmic load
120 V DC-0.1 A
250 V AC-0.5 A

International Standards

Ambient Conditions

Storage temperature: -20 to $+80$ °C

Operating temperature 0 to $+55$ °C

Humidity class: 0 to 95 %

without moisture condensation

Protection class Front: IP 41

Housing: IP 30

Electromagnetic Compatibility (EMC)

Electromagnetic Immunity

DIN EN

61000-4-2 ESD; contact discharge 4 kV

air discharge 8 kV

61000-4-3 EM-HF-field; 10 V/m

61000-4-4 Burst

Signal-Inputs: 1 kV

Power Supply: 2 kV

61000-4-5 Surge

Signal-Inputs sym.: 1 kV

Power Supply sym.: 1 kV

Power Supply asym.: 2 kV

61000-4-6 HF inflow: 10 V

61000-4-8 50 Hz magnetic fields

continuous field: 30 A/m

Electromagnetic Emission

DIN EN 55011 Radio noise emission Group 1, Class A

Electric Safety

DIN EN 50178 Quality requirements

IEC 60255-5 Isolation strength

Signal-Inputs: Class 3

Power Supply: Class 2

Connection Technology

Phoenix[®]-plugs: COMBICON FKC 2,5

Maximum conductor cross section:

one-strand 0.20 to 2.5 mm²

fine-strand 0.20 to 2.5 mm²

fine-strand 0.25 to 2.5 mm² with
DIN 46 228 end splice

ME 3011E / Alarm Indication / Quick Reference Guide

Control and Monitoring Elements

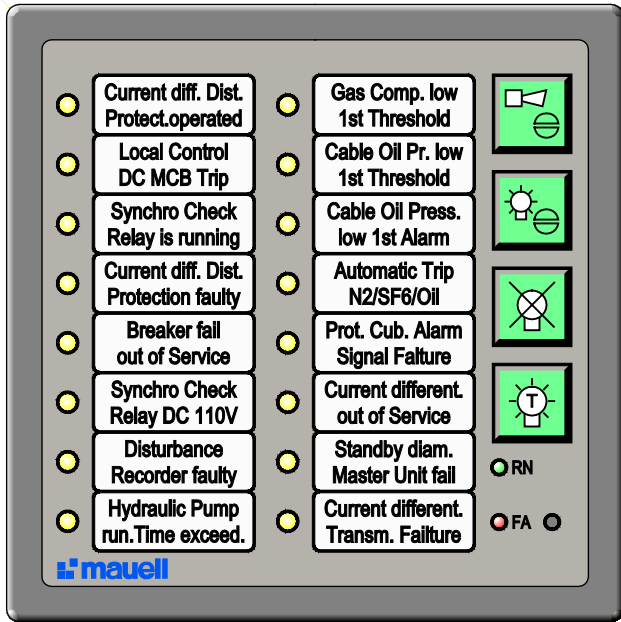

Digital Alarm Annunciator with 16 Signals

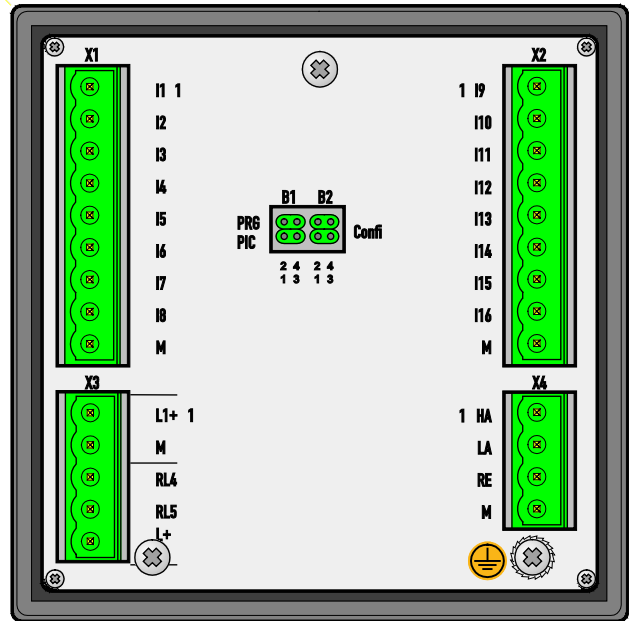

Rear View

Push-Buttons



Horn acknowledge (HA)
stops the horn/buzzer.



Lamp acknowledge (LA)
makes flashing light permanently on or off, depending on the configured alarm sequence.



Lamp Reset (RE)
resets the alarm; depending on the configured alarm sequence



Lamp or Functional Test (LT/FT)
Lamp-Test turns all equipment LEDs on Functional-Test simulates an alarm condition in all points, depending on the configured alarm sequence

Sound Signal

- **Buszzer / Horn**

LED Indication

LED RN	green	system is operative
LED FA	red	Faulty Annunciator
		Flashes different from the alarm sequence.
LED Mid1 - n	yellow	Alarm is on

Dimension Drawing

Front View

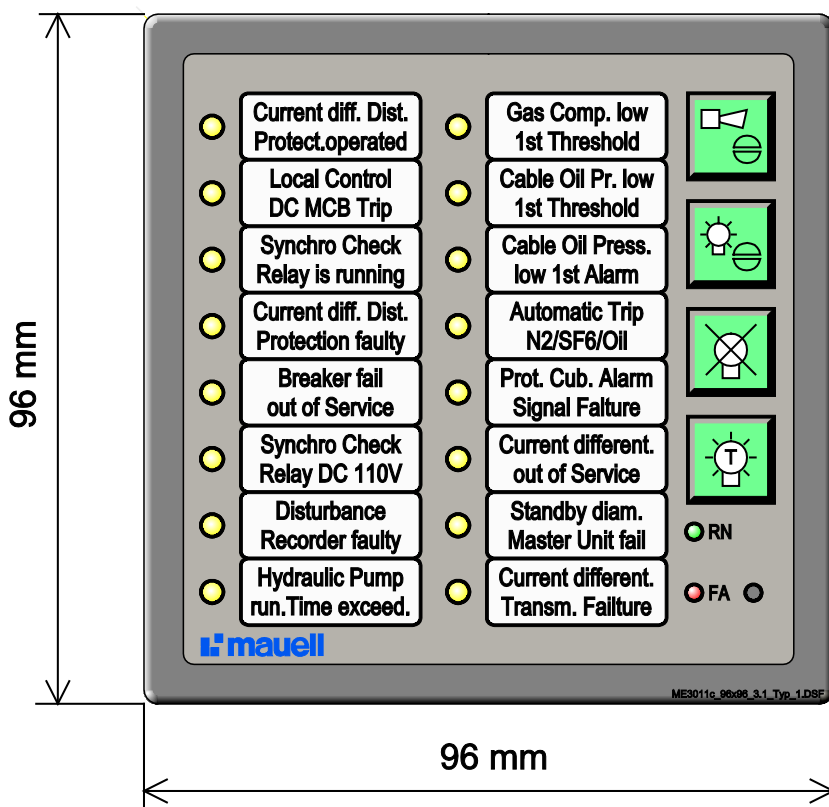

Front view from a Digital Alarm Annunciator with 16 MId

Side View

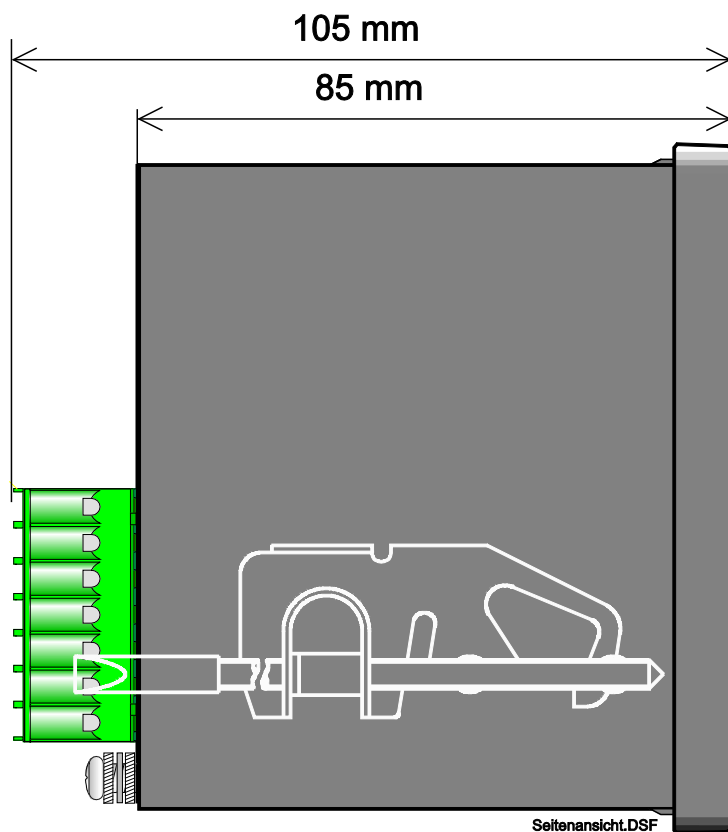

Side view from a Digital Alarm Annunciator

ME 3011E / Alarm Indication / Quick Reference Guide

Labeling of the Messages

The messages are using paper labels.

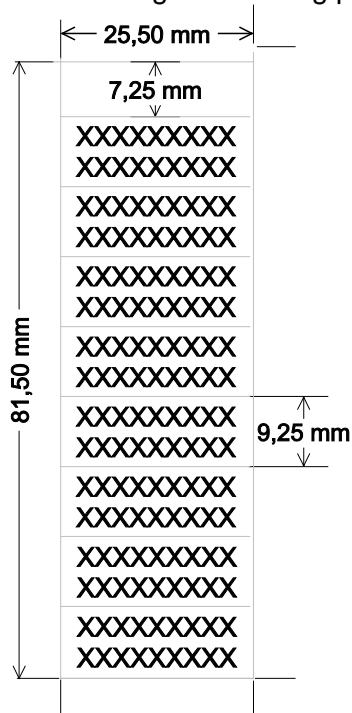

The paper, at a weight of 100 g / m², should not be thicker than 1/10 mm.

You will find a corresponding PDF form under 3011 on our website

<http://www.mauell.bilfinger.com>.

Panel Mounting

The Digital Alarm Annunciator is mounted with spannstücke in the cut-out of the front-panel (see Side View).

Cut-out size for panel mounting (WxH):
16 alarms 91 x 91 mm

The installation depth is deeper than 110 mm.

Spacing of the modules

During the assembly of the modules, you have to ensure that the minimum upwards and downwards spacing is more than 50 mm.

Spare Parts

- | | |
|-----------|--|
| 08-40-026 | Befestigungsspanne DIN 43835 (panel clamp) |
| 06-73-054 | Programming Adapter; 0,5 m (Pin 1 is marked) |
| 01-35-354 | RJ11-RS 232 Prog. cable 5 m |



POWER SYSTEMS

Bilfinger Mauell GmbH
Am Rosenhügel 1-7
42553 Velbert
Deutschland
Telefon +49 2053 13-0
Fax +49 2053 13-403
info@mauell.com
www.mauell.bilfinger.com

