

# ISOMETER® IRDH275

Insulation monitoring device for unearthed  
AC, AC/DC and DC systems (IT systems)



# ISOMETER® IRDH275

Insulation monitoring device for unearthed AC, AC/DC and DC systems (IT systems)



ISOMETER® IRDH275

## Device features

- Insulation monitoring for unearthed AC, AC/DC systems 0...793 V, DC 0...650 V
- Nominal voltage extendable via coupling device
- Two separately adjustable response values 1 kΩ...10 MΩ
- **AMP<sup>Plus</sup>** measurement method
- Automatic adaptation to the system leakage capacitance
- Info button to display device settings and system leakage capacitance
- Self monitoring with automatic alarm
- Automatic self test, selectable
- Connection for external kΩ indication
- Test and reset button
- External test/reset button can be connected
- Two separate alarm relays with two potential-free changeover contacts
- N/O or N/C operation, selectable
- Backlit LC display
- RS-485 interface

## Approvals



## Product description

The ISOMETER® of the IRDH275 series is designed to monitor the insulation resistance of unearthed main circuits (IT systems) AC, AC/DC 0...793 V resp. DC 0...650 V. The **AMP<sup>Plus</sup>** measurement method meets the particular requirements of modern power supplies which often include rectifiers, converters, thyristor-controlled DC drives and directly connected DC components. In these systems often high leakage capacitances against earth occur due to interference suppression measures. The IRDH275 automatically adapts itself to the existing system conditions.

In combination with a coupling device, the devices can also be used for higher voltages. An external supply voltage allows de-energised systems to be monitored too. For door mounting into distribution panels, refer to type IRDH375(B).

## Application

- AC, DC or AC/DC main circuits
- AC/DC main circuits with directly connected DC components, such as rectifiers, converters, and thyristor-controlled DC drives
- UPS systems, battery systems
- Heaters with phase control
- Installations including switch-mode power supplies
- IT systems including high leakage capacitances
- Coupled IT systems

## Function

When the insulation resistance between the system conductors and earth falls below the set response value, the alarm relays switch and the alarm LEDs light up. Two separately adjustable alarm relays allow to distinguish between prewarning and alarm. The measured value is indicated on the LC display or an externally connectable measuring instrument. In this way any changes, for example when circuits are connected to the system, can be recognised easily. The fault message can be stored. The fault memory can be reset by pressing the reset button. By pressing the test button, the function of the device as well as the connections to system and earth can be tested. Pressing the Info button provides additional information, such as the existing system leakage capacitance or device settings.

The function of the device and the system and earth connections are continuously monitored. When a fault occurs, the system fault relay switches and the alarm LED "system fault" lights up. The parameterisation of the device can be carried out via the LC display or the function buttons integrated in the front plate.

## Device version IRDH275B

Device version IRDH275B includes the following additional functions:

- History memory with real-time clock to store all alarm messages with date and time stamp
- Electrically isolated RS-485 interface (BMS protocol) for communication with other Bender devices
- Isometer disconnecting relays for the operation of several ISOMETER®s in coupled IT systems
- Current output 0(4)...20 mA (electrically isolated)

## Use in coupled IT systems

Only one ISOMETER® may be active when several IT systems are coupled. Isometer disconnecting relays and the control inputs F1/F2 integrated in version IRDH275B guarantee that only one ISOMETER® is active at any one time.

## Measurement method

**AMP<sup>Plus</sup>** The IRDH275(B) uses the patented **AMP<sup>Plus</sup>** measurement method. This measurement method allows concise monitoring of modern power supply systems, also in case of extensive, directly connected DC components and high system leakage capacitances.

## Standards

The ISOMETER® of the IRDH275 series complies with the requirements of the device standards: DIN EN 61557-8 (VDE 0413-8), EN 61557-8, IEC 61557-8, IEC 61326-2-4, DIN EN 60664-1 (VDE 0110-1), DIN EN 60664-3 (VDE 0110-3), ASTM F1669M-96 (2007), ASTM F1207M-96 (2007)

Operating elements IRDH275

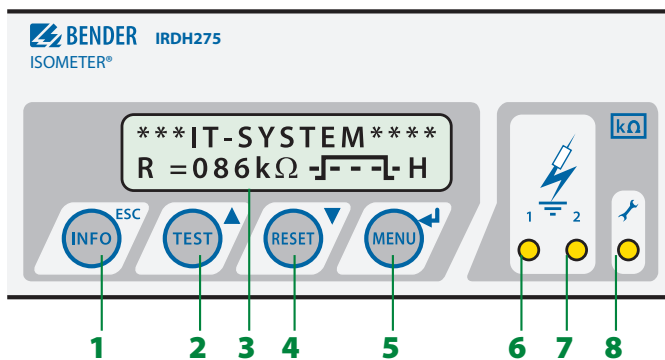

- 1 - "INFO" button: to query standard information  
ESC button: back to the menu function
- 2 - "TEST" button: to call up the self test  
Arrow up button: Parameter changes, scroll
- 3 - "RESET" button: to delete alarm and fault messages  
Arrow down button: Parameter change, scroll.
- 4 - "MENU" button: to activate the menu system  
Enter button: to confirm parameter changes
- 5 - Alarm LED "1" lights: insulation fault, 1st warning level reached
- 6 - Alarm LED "2" lights: insulation fault, 2nd warning level reached
- 7 - LED lights: system fault
- 8 - LC display

Response times

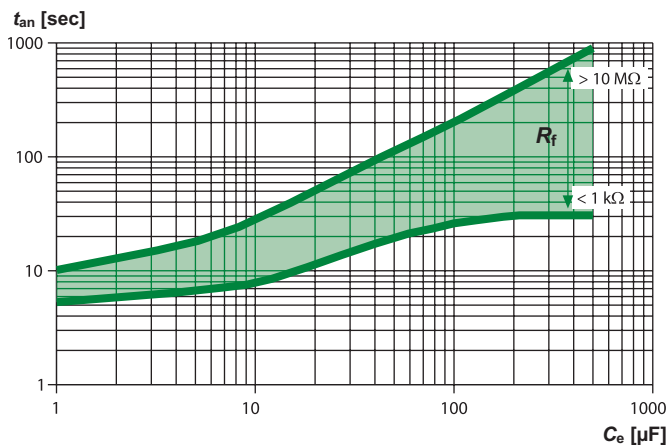

ISOMETER® response times in relation to the system leakage capacitances:  $C_e = 1 \dots 500 \mu F$ ,  $U_n = 0 \dots 793 V/50 Hz$

Wiring diagram

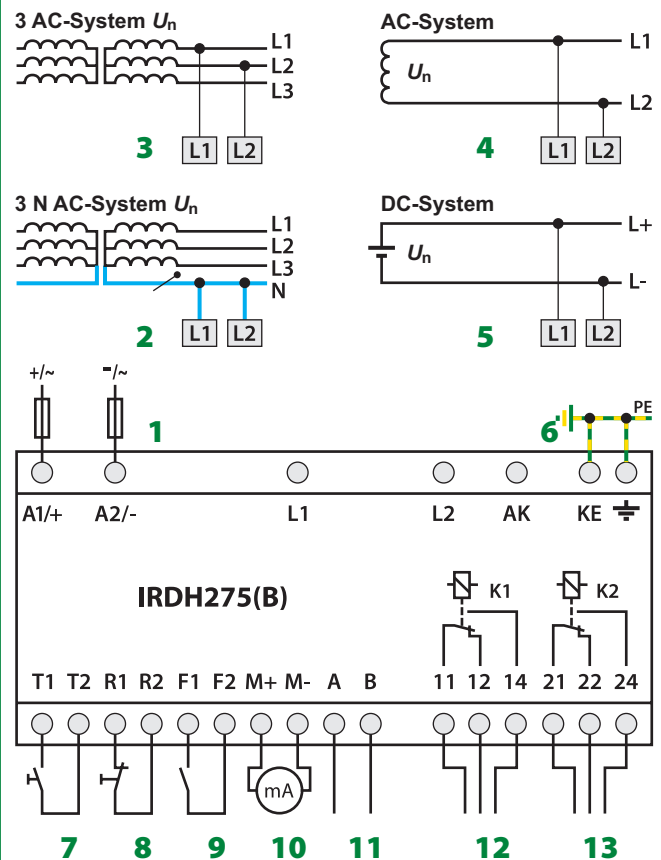

- 1 - Supply voltage  $U_s$  (see ordering information) via 6 A fuse; for UL and CSA applications, it is mandatory to use 5 A fuses.
  - 2,3 - Connection to the 3AC system being monitored: Connect the terminals L1, L2 to neutral conductor N or terminals L1, L2 to conductor L1, L2.
  - 4 - Connection to the AC system to be monitored: Connect terminals L1, L2 to conductor L1, L2.
  - 5 - Connection of the DC systems being monitored: Connect terminal L1 to conductor L+, terminal L2 to conductor L-
  - 6 - Separate connection of the equipotential bonding conductor to PE and KE
  - \*7 - External test button "T1/T2" (N/O contact)
  - \*8 - External reset button "R1/R2" (N/C contact or wire jumper)  
When the terminals are open, the fault message will not be stored, provided that the memory has not been activated via the operating menu.
  - \*9 - STANDBY by means of the function input "F1, F2": with the contact in closed position no insulation measurement takes place (Isometer disconnection B version only/no disconnection when operated via AK).
  - 10 - IRDH275: Current output, electrically isolated:  $0 \dots 400 \mu A$   
IRDH275B: Current output, electrically isolated:  $0 \dots 20 mA$  or  $4 \dots 20 mA$
  - 11 - RS-485 interface
  - 12 - Alarm relay: Alarm 1
  - 13 - Alarm relay: Alarm 2/system
- \* The terminal pairs 7, 8 and 9 must be wired galvanically isolate and must not have a connection to PE!

**Ordering information**

| RS-485 interface | Coupled IT systems | Output                            | Supply voltage $U_3^{1)}$ |             | Type         | Art. No.    |
|------------------|--------------------|-----------------------------------|---------------------------|-------------|--------------|-------------|
|                  |                    |                                   | AC                        | DC          |              |             |
| ASCII-IsoData    | not applicable     | Current output<br>0...400 $\mu$ A | 88...264 V                | 77...286 V  | IRDH275-435  | B 9106 5100 |
|                  |                    |                                   | –                         | 19.2...72 V | IRDH275-427  | B 9106 5104 |
|                  |                    |                                   | –                         | 10.2...36 V | IRDH275-425  | B 9106 5108 |
| BMS              | applicable         | Current output<br>0(4)...20 mA    | 88...264 V                | 77...286 V  | IRDH275B-435 | B 9106 5101 |
|                  |                    |                                   | –                         | 19.2...72 V | IRDH275B-427 | B 9106 5105 |
|                  |                    |                                   | –                         | 10.2...36 V | IRDH275B-425 | B 9106 5109 |

<sup>1)</sup> Absolute values

Device "Option-W" with increased shock and vibration resistance: Indicated by the letter "W" at the end of the order number.

**Suitable system components**

| Type designation                          | Type      | Page        |
|---|-----------|-------------|
| External k $\Omega$ measuring instruments | 7204-1421 | B 986 763   |
|   | 9604-1421 | B 986 764   |
|   | 9620-1421 | B 986 841   |
| Coupling devices                          | AGH150W-4 | B 9801 8006 |
|   | AGH204S-4 | B 914 013   |
|   | AGH520S   | B 913 033   |

**Maßbild XM112**

Maßangabe in mm

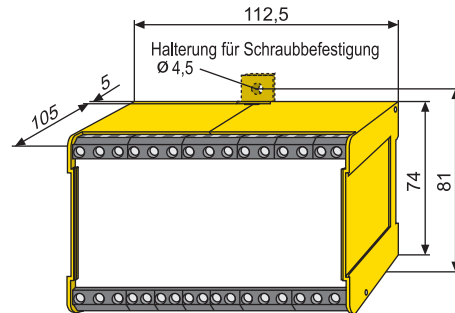

**Wiring diagrams – IRDH275 connected to different types of coupling devices**

**ISOMETER® IRDH275 with coupling device AGH150W-4**

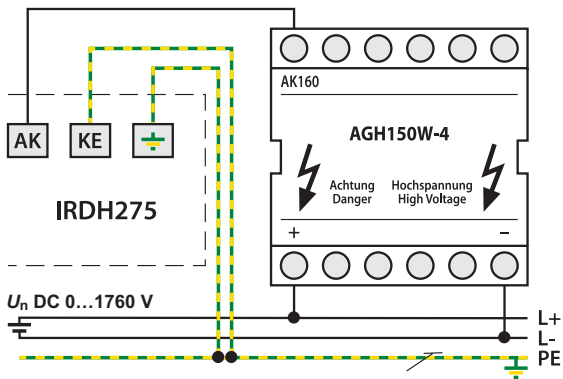

**ISOMETER® IRDH275 with coupling device AGH204S-4**

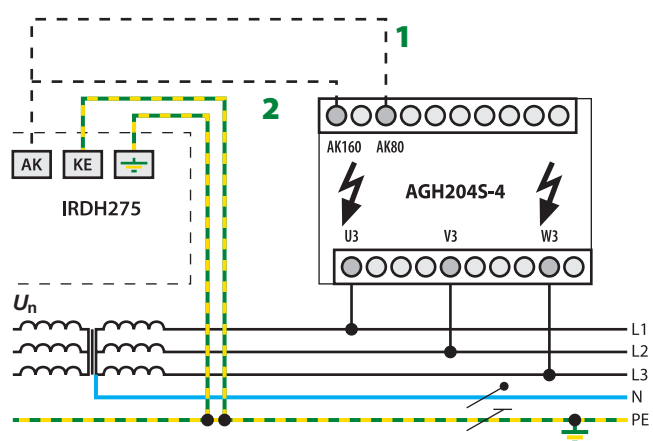

1 - without rectifier

$U_n = 3AC\ 0...1650\ V\ (DC\ max.\ 1000\ V)$

2 - with rectifier

$U_n = 3AC\ 0...1300\ V\ (peak\ voltage\ downstream\ of\ the\ rectifier\ or\ DC\ voltage\ intermediate\ circuit\ of\ max.\ 1840\ V)$

**ISOMETER® IRDH275 with coupling device AGH520S**

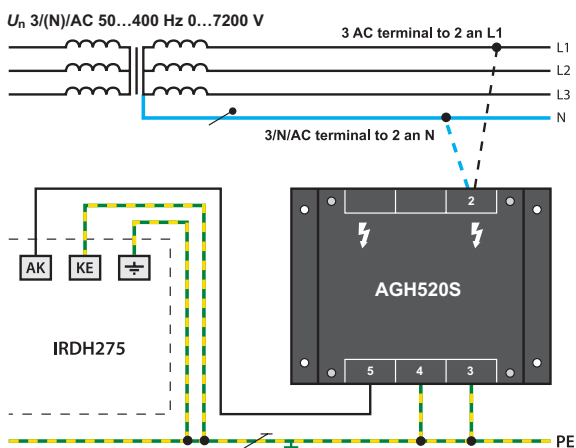

**Technical data**
**Insulation coordination acc. to IEC 60664-1**

|  |          |
|--|----------|
| Rated insulation voltage               | AC 800 V |
| Rated impulse voltage/pollution degree | 8 kV/3   |

**Voltage ranges**

|                              |                        |
|------------------------------|------------------------|
| <b>IRDH275...:</b>           |                        |
| Nominal system voltage $U_n$ | AC, 3/(N)AC 0...793 V* |
| Nominal frequency $f_n$      | 50...460 Hz            |
| Nominal system voltage $U_n$ | DC 0...650 V*          |

**IRDH275...-435:**

|   |                |
|---|----------------|
| Supply voltage $U_S$ (also see nameplate) | AC 88...264 V* |
| Frequency range $U_S$                     | 42...460 Hz    |
| Supply voltage $U_S$ (also see nameplate) | DC 77...286 V* |

**IRDH275...-427:**

|   |                 |
|---|-----------------|
| Supply voltage $U_S$ (also see nameplate) | DC 19.2...72 V* |
|---|-----------------|

**IRDH275...**

|                   |         |
|-------------------|---------|
| Power consumption | ≤ 14 VA |
|-------------------|---------|

**Response values**

|   |              |
|---|--------------|
| Response value $R_{an1}$ (Alarm1)                                       | 1 kΩ...10 MΩ |
| Response value $R_{an2}$ (Alarm2)                                       | 1 kΩ...10 MΩ |
| Relative uncertainty (20 kΩ...1 MΩ) (acc. to IEC 61557-8)               | ± 15 %       |
| Relative uncertainty (1...20 kΩ +2 kΩ/+20 %)                            |              |
| Relative uncertainty (1...10 MΩ)  | 0.2 kΩ/+20 % |
| Response time $t_{an}$ at $R_F = 0.5 \times R_{an}$ and $C_e = 1 \mu F$ | ≤ 5 s        |
| Hysteresis (1...10 kΩ)  | +2 kΩ        |
| Hysteresis (10 kΩ...10 MΩ)  | 25 %         |

**Measuring circuit**

|  |             |
|--|-------------|
| Measuring voltage $U_m$                        | ≤ 50 V      |
| Measuring current $I_m$ (at $R_F = 0 \Omega$ ) | ≤ 280 μA    |
| Internal DC resistance $R_i$                   | ≥ 180 kΩ    |
| Impedance $Z_i$ at 50 Hz                       | ≥ 180 kΩ    |
| Permissible extraneous DC voltage $U_{fg}$     | ≤ DC 1200 V |
| Permissible system leakage capacitance         | ≤ 500 μF    |
| Factory setting                                | 150 μF      |

**Displays**

|   |                   |
|---|-------------------|
| Display, illuminated                                    | two-line display  |
| Characteristics (number)                                | 2 x 16            |
| Display range measured value                            | 1 kΩ...10 MΩ      |
| Operating uncertainty (20 kΩ...1 MΩ) (nach IEC 61557-8) | ± 15 %**          |
| Operating uncertainty (1...20 kΩ)                       | ± 1 kΩ/± 15 %**   |
| Operating uncertainty (1...10 MΩ)                       | ± 0.1 MΩ/± 15 %** |

**Outputs/Inputs**

|   |                    |
|---|--------------------|
| Test/reset button   | internal/external  |
| Cable length test/reset button, external                                    | ≤ 10 m             |
| Current output for measuring instrument SKMP (scale centre point = 120 kΩ): |                    |
| Current output IRDH275 (load)   | 400 μA (≤ 12.5 kΩ) |
| Current output IRDH275B (load)  | 20 mA (≤ 500 Ω)    |
| Accuracy current output (1 kΩ...1 MΩ) related to the value indicated        | ±10 %, ±1 kΩ       |

**Serial interface**

|   |                                    |
|---|------------------------------------|
| Interface/protocol IRDH275                                  | RS-485/ASCII-IsoData               |
| Interface/protocol IRDH275B                                 | RS-485/BMS                         |
| Connection  | terminals A/B                      |
| Cable length  | ≤ 1200 m                           |
| Cable (twisted in pairs, one end of shield connected to PE) | recommended: J-Y(St)Y min. 2 x 0.8 |
| Terminating resistor  | 120 Ω (0.5 W)                      |
| Device address, BMS bus                                     | 1...30 (factory setting = 3)       |

**Switching elements**

|  |   |
|--|---|
| Switching elements                           | 2 changeover contacts: K1 (Alarm 1), K2 (Alarm 2, device error) |
| Operating principle K1, K2 (Alarm 1/Alarm 2) | N/O or N/C operation  |
| Factory setting (Alarm 1/Alarm 2)            | N/O operation   |
| Electrical endurance, number of cycles       | 12000   |
| Contact class                                | IIB (DIN IEC 60255-23)  |
| Rated contact voltage                        | AC 250 V/DC 300 V   |
| Making capacity                              | AC/DC 5 A   |
| Breaking capacity                            | 2 A, AC 230 V, cos phi = 0.4<br>0.2 A, DC 220 V, L/R = 0.04 s   |
| Contact rating at DC 24 V                    | ≥ 2 mA (50 mW)  |

**Environment/EMC**

|  |                               |
|--|-------------------------------|
| EMC  | acc. to IEC 61326-2-4 Ed. 1.0 |
| Shock resistance IEC 60068-2-27 (device in operation)    | 15 g/11 ms                    |
| Bumping IEC 60068-2-29 (transport)                       | 40 g/6 ms                     |
| Vibration resistance IEC 60068-2-6 (device in operation) | 1 g/10...150 Hz               |
| Vibration resistance IEC 60068-2-6 (transport)           | 2 g/10...150 Hz               |
| Ambient temperature (during operation)                   | -10...+55 °C                  |
| Ambient temperature (during storage)                     | -40...+70 °C                  |
| Climatic class acc. to IEC 60721-3-3                     | 3K5                           |

**Connection**

|  |  |
|--|--|
| Connection   | screw-type terminals                               |
| Connection properties                              |  |
| rigid/flexible                                     | 0.2...4 mm <sup>2</sup> /0.2...2.5 mm <sup>2</sup> |
| flexible with ferrules without/with plastic sleeve | 0.25...2.5 mm <sup>2</sup>                         |
| Tightening torque                                  | 0.5 Nm   |
| Conductor sizes (AWG)                              | 24...12  |

**Other**

|  |                         |
|--|-------------------------|
| Operating mode   | continuous operation    |
| Mounting   | display-oriented        |
| Distance to adjacent devices                             | ≥ 30 mm                 |
| Degree of protection, internal components (DIN EN 60529) | IP30                    |
| Degree of protection, terminals (DIN EN 60529)           | IP20                    |
| Type of enclosure  | X112, free from halogen |
| DIN rail mounting  | DIN EN 60715/IEC 60715  |
| Flammability class                                       | UL94 V-0                |
| Software version IRDH275                                 | D160 V1.4               |
| Software version IRDH275B                                | D159 V1.4               |
| Operating manual   | TGH1361                 |
| Weight   | ≤ 510 g                 |

**Option "W"**

|   |                                      |
|---|--------------------------------------|
| Shock resistance IEC 60068-2-27 (device in operation) | 30 g/11 ms                           |
| Bumping IEC 60068-2-29 (transport)                    | 40 g/6 ms                            |
| Vibration resistance IEC 60068-2-6                    | 1.6 mm/10...25 Hz<br>4 g/25...150 Hz |
| Ambient temperature (during operation)                | -40...+70 °C                         |
| Storage temperature range - 40...+85 °C               |                                      |
| Screw mounting  | 2 x M4                               |

The data labelled with an \* are absolute values

\*\* = Under EMC test conditions in accordance with IEC 61326-2-4 the specified tolerances can double



**Bender GmbH & Co. KG**

P.O. Box 1161 • 35301 Grünberg • Germany  
Londorfer Straße 65 • 35305 Grünberg • Germany  
Tel.: +49 6401 807-0 • Fax: +49 6401 807-259  
E-Mail: [info@bender-de.com](mailto:info@bender-de.com) • [www.bender-de.com](http://www.bender-de.com)

**BENDER Group**