

## ISOMETER® IR420-D6

Offline monitor for de-energised AC, DC and 3(N)AC loads  
in TN,TT and IT systems



# ISOMETER® IR420-D6

Offline monitor for  
de-energised AC, DC and 3(N)AC loads  
in TN,TT and IT systems



ISOMETER® IR420-D6

## Device features

- Insulation monitoring for de-energised TN, TT and unearthed systems AC, 3(N)AC and DC
- Nominal voltage extendable via coupling device
- Two separately adjustable response values 100 kΩ...10 MΩ
- LEDs: Power On LED, LEDs Alarm 1, Alarm 2 for signalling insulation faults
- Combined test/reset button
- Two separate alarm relays with one changeover contact each
- Fault memory behaviour, selectable
- Push-wire terminal (two terminals per connection)

## Approvals



## Product description

The offline monitor of the IR420-D6 series monitors the insulation resistance of de-energised loads. These loads, usually temporarily operated or de-energised most of the time, e.g. fire extinguisher pumps, slide valve drives, elevator motors, emergency power generators etc., are supplied from TN, TT or IT systems. During the shut-down periods, however, humidity or other effects may cause insulation faults in the wiring or the loads which may go undetected. Switching the device on may then lead to the tripping of the protective device or may even result in motor fires and the device cannot be operated. In combination with a coupling device, the devices can also be used for higher voltages.

## Application

- De-energised loads such as automatic fire extinguisher pumps, emergency drives, ship cranes, slide-valve drives in supply lines (gas, water, oil), motor-driven closing systems, diving pumps, drives for anchors, elevators, flue-gas valves and emergency power generators

## Function

When the insulation resistance between the system conductors and earth falls below the set response value, the alarm relays switch and the alarm LEDs light up. The measured value is indicated on the internal LC display. In this way any changes, for example when circuits are connected to the system, can be recognised easily. The fault memory can be reset by pressing the reset button. The device function can be tested using the test button. Two separately adjustable response values with one alarm relay each allow prewarning already in case of very high-resistance insulation faults. When the lower response level is reached, an interlocking function will be activated and the connection of a defective load can be prevented.

The insulation resistance is measured via the output L1 or via a contact to the system being monitored. The contact is controlled via the external contact element K3. With the contact in closed position, the system is de-energised and the insulation resistance is being measured. If the system or load is in operation, K3 opens the contact and insulation monitoring is deactivated. Make sure that the main switch disconnects all poles. To ensure that the measuring voltage can be superimposed onto the system, a low-resistance connection must exist between all line conductors (e.g. by motor windings).

Note: If the IR420-D6 is operated via a coupling device, the auxiliary contact (N/C contact) of K3 between the ISOMETER® and the coupling device need not to be designed for the nominal voltage of the system. A rated contact voltage of AC 230 V will be sufficient here.

## Measurement method



Superimposed DC voltage with inverter.

## Standards

The ISOMETER® of the IR420 D6 series complies with the requirements of the device standards: DIN EN 61557-8 (VDE 0413-8), EN 61557-8, IEC 61557-8, IEC 61326-2-4, DIN EN 60664-1 (VDE 0110-1), DIN EN 60664-3 (VDE 0110-3), ASTM F1669M-96 (2007), ASTM F1207M-96 (2007)

Operating elements

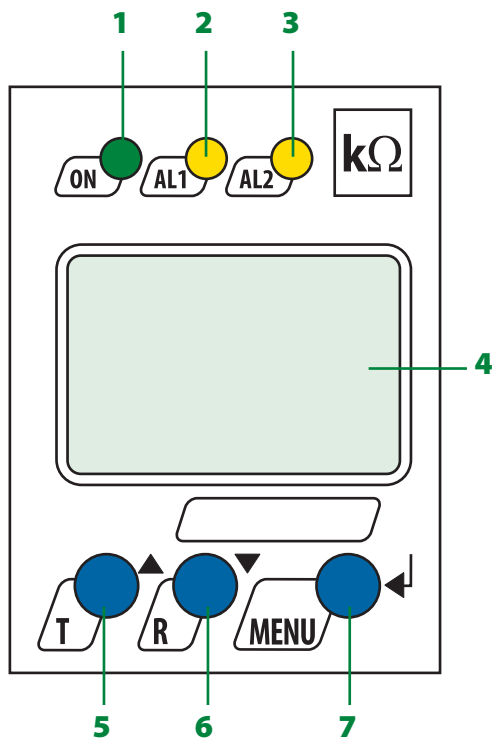

- 1 - Power On LED "ON", flashes in case of interruption of the connecting leads E/KE
- 2 - Alarm LED "AL1", lights when the value falls below the set response value Alarm 1 and flashes in case of interruption of the connecting leads E/KE
- 3 - Alarm LED "AL2", lights when the value falls below the set response value Alarm 2 and flashes in case of interruption of the connecting leads E/KE
- 4 - LC display
- 5 - Test button "T": to call up the self test.  
Arrow up button: parameter change, to move up in the menu
- 6 - Reset button "R": to delete stored insulation fault alarms  
parameter change, to move down in the menu
- 7 - "MENU" button: to call up the menu system.  
Enter button: to confirm parameter changes

Wiring diagrams (examples)

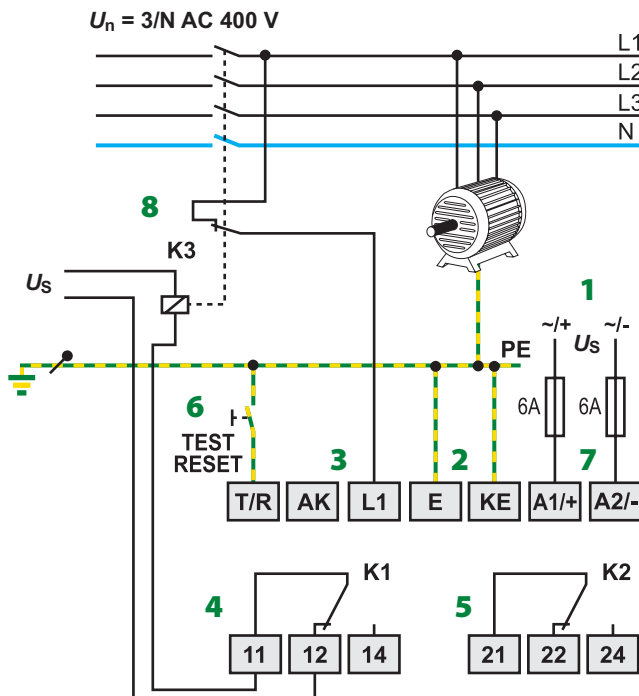

- 1 - Supply voltage  $U_s$  (see ordering details) via fuse
- 2 - Separate connection of E, KE to PE
- 3 - Connection of the AC system to be monitored:
- 4 - Alarm relay "K1": Alarm 1
- 5 - Alarm relay "K2": Alarm 2

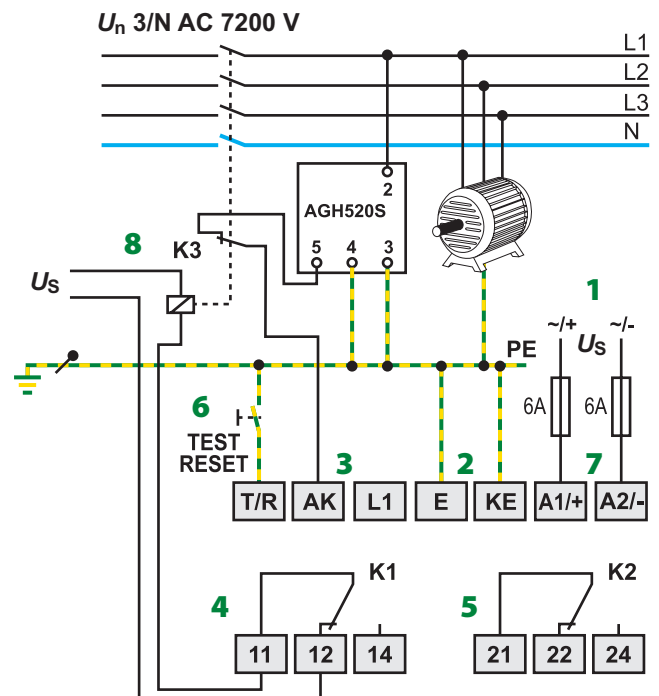

- 6 - Combined test and reset button "TEST RESET"  
short-time pressing (< 1.5 s) = RESET  
long-time pressing (> 1.5 s) = TEST
- 7 - Line protection by a fuse in accordance with IEC 60364-4-43 (6 A fuse recommended). In case of supply (A1/A2) from an IT system, both lines have to be protected by a fuse.
- 8 - K3 is also required and is not included in IR420-D6

## Technical data

### Insulation coordination acc. to IEC 60664-1/IEC 60664-3

Rated insulation voltage	400 V
Rated impulse voltage/pollution degree	4 kV/3
Protective separation (reinforced insulation) between (A1, A2) – (L1, AK, E, KE, T/R) – (11, 12, 14) – (21, 22, 24)	
Voltage test acc. to IEC 61010-1	2.21 kV

### Supply voltage

Supply voltage $U_s$	see ordering information
Power consumption	$\leq 3$ VA

### IT system being monitored

Nominal system voltage $U_n$	off-line
without AGH	nominal contact voltage of the N/C contact of K3 (switch-on contactor)
with AGH520S	AC 0...7200 V, 50...400 Hz

### Response values

Response value $R_{an1}$ (Alarm 1)	100 k $\Omega$ ...10 M $\Omega$ (1 M $\Omega$ )*
Response value $R_{an2}$ (Alarm 2)	100 k $\Omega$ ...10 M $\Omega$ (100 k $\Omega$ )*
Relative uncertainty	$\pm 15$ %
Hysteresis	25 %

### Time response

Response time $t_{an}$ at $R_F = 0.5 \times R_{an}$ and $C_e = 1 \mu F$	$\leq 4$ s
Start-up delay (start time) $t$	0...10 s (0 s)*
Response delay $t_{on}$	0...99 s (0 s)*

### Measuring circuit

Measuring voltage $U_m$	$\pm 12$ V
Measuring current $I_m$ (at $R_F = 0 \Omega$ )	$\leq 10 \mu A$
Internal DC resistance $R_i$	$\geq 1.2$ M $\Omega$
Impedance $Z_i$ at 50 Hz	$\geq 1.1$ M $\Omega$
Permissible extraneous DC voltage $U_{fg}$	$\leq$ DC 300 V
Permissible system leakage capacitance $C_e$	$\leq 10 \mu F$

### Displays, memory

Display range, measured value	10 k $\Omega$ ...20 M $\Omega$
Operating uncertainty	$\pm 15$ %
Password	off/0...999 (off)*
Fault memory alarm relay	on/off (off)*

### Outputs

Cable length test and reset button	$\leq 10$ m
------------------------------------	-------------

### Switching elements

Number of switching elements	2 x 1 changeover contact				
Operating principle	NC or N/O operation (N/O operation)*				
Electrical service life, number of cycles	10000				
Contact data acc. to IEC 60947-5-1					
Utilisation category	AC-13	AC-14	DC-12	DC-12	DC-12
Rated operational voltage	230 V	230 V	220 V	110 V	24 V
Rated operational current	5 A	3 A	0.1 A	0.2 A	1 A
Minimum contact rating	1 mA at AC/DC > 10 V				

### Environment/EMC

EMC	IEC61326-2-4
Operating temperature	-25...+55 °C
Climatic class acc. to IEC 60721	
Stationary use (IEC 60721-3-3)	3K5 (except condensation and formation of ice)
Transport (IEC 60721-3-2)	2K3 (except condensation and formation of ice)
Long-time storage (IEC 60721-3-1)	1K4 (except condensation and formation of ice)
Classification of mechanical conditions IEC 60721	
Stationary use (IEC 60721-3-3)	3M4
Transport (IEC 60721-3-2)	2M2
Long-time storage (IEC 60721-3-1)	1M3

### Connection

Connection type	push-wire terminal
Connection properties	
rigid	0.2...2.5 mm <sup>2</sup> (AWG 24...14)
flexible without ferrule	0.2...2.5 mm <sup>2</sup> (AWG 24...14)
flexible with ferrule	0.2...1.5 mm <sup>2</sup> (AWG 24...16)
Stripping length	10 mm
Opening force	50 N
Test opening, diameter	2.1 mm

### Other

Operating mode	continuous operation
Mounting	any position
Degree of protection, internal components (DIN EN 60529)	IP30
Degree of protection, terminals (DIN EN 60529)	IP20
Enclosure material	polycarbonate
Screw mounting	2 x M4 with mounting clip
DIN rail mounting acc. to	IEC 60715
Operating manual	TBP101014
Weight	$\leq 150$ g

( ) \* = Factory setting

**Ordering information**

Supply voltage <sup>1)</sup> U <sub>S</sub>		Type	Art. No.
DC	AC		
9.6...94V	16...72V, 42...460Hz	IR420-D6-1	B 7101 6415
70...300V	70...300V, 42...460Hz	IR420-D6-2	B 7101 6407

Device version with screw terminals on request.

<sup>1)</sup> Absolute values

**Accessories**

Type designation	Art. No.
Mounting clip for screw mounting (1 piece per device)	B 9806 0008

**Suitable system components**

Type designation	Type	Art. No.
Coupling device	AGH520S	B 913 033

**Dimension diagram XM420**

Dimensions in mm

Open the front plate cover in direction of arrow!

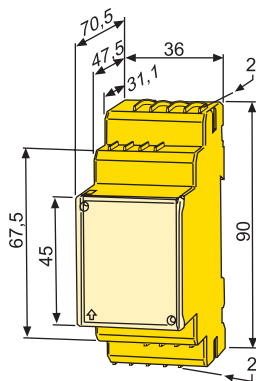

**Screw mounting**

Note: The upper mounting clip must be ordered separately (see ordering information).

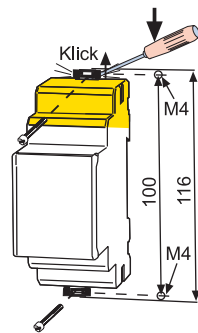



**Bender GmbH & Co. KG**

P.O. Box 1161 • 35301 Grünberg • Germany  
Londorfer Straße 65 • 35305 Grünberg • Germany  
Tel.: +49 6401 807-0 • Fax: +49 6401 807-259  
E-Mail: [info@bender-de.com](mailto:info@bender-de.com) • [www.bender-de.com](http://www.bender-de.com)

**BENDER Group**