

NEW! FREJA 549 Relay Test System

FREJA 549
Relay Test System

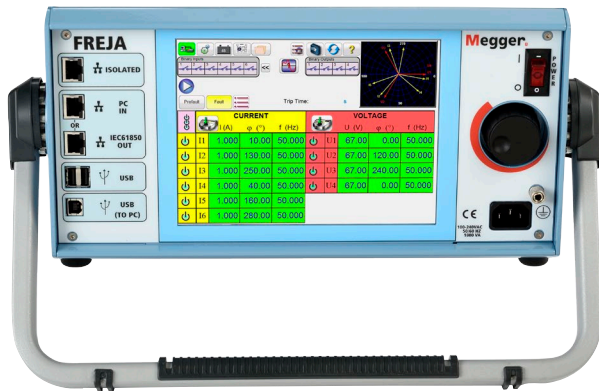

- Fully automated testing using FREJA Win software
- Stand-alone operation using intuitive high resolution graphic touchscreen, no PC required to operate
- High current, high power output – up to 60 Amps / 300 VA rms per phase
- Provides up to 9 currents for testing transformer and bus differential relay
- Dynamic GPS Satellite Synchronized End-to-End Testing Capability
- IEC 61850 Testing Capability

DESCRIPTION

The FREJA 549 is a multipurpose, light-weight, field portable relay test set from Megger. The unit can be operated either manually via the built-in touch-screen user interface running FREJA Local, or placed under full computer control via the FREJA Win Software.

The built-in user interface is Megger's second generation of automatic / semi-automatic manual user interface running the FREJA Local software. The large, easy to read Full Color high resolution, high definition, TFT LCD touch-screen display allows the user to perform manual, steady-state and dynamic testing quickly and easily.

FREJA Local includes built-in preset test routines for automatic testing. Menu screens and touch screen function buttons are provided to quickly and easily select the desired test function. Tests and results can be saved in FREJA Local memory and downloaded to a USB memory stick for transfer or print test reports. For full automatic testing the FREJA Win software will be used with a PC. There are number of instrument programs to test virtually any protection. Since the test set-ups/results are saved via regular Microsoft Explorer display, you can create your own test object structure.

The FREJA 549 has the "smart" combination of high compliance voltage to test high impedance earth fault relays, and high current to test all electromechanical, solid-state and numerical-based overcurrent relays, including voltage controlled, voltage restraint and directional overcurrent.

APPLICATIONS

The FREJA 549 is primarily designed for secondary testing of protection relays. Virtually all types can be tested.

Examples of what FREJA can test	ANSI® / IEEE No.
Distance protection relay	21
Over fluxing relays	24
Synchronising or synchronism-check relays	25
Under Voltage relays	27
Directional Power relays	32
Under Current or Under Power relays	37
Loss of field relays	40
Negative sequence overcurrent relays	46
Phase sequence voltage relays	47
Overcurrent-/ ground fault relays	50
Inverse time overcurrent-/ ground fault relays	51
Power factor relays	55
Overvoltage relays	59
Voltage or current balance relays	60
Directional overcurrent relays	67
DC overcurrent relays	76
Out-of-step protection relays	78
Automatic reclosing devices	79
Frequency relays	81
Carrier or pilot wire	85
Differential protection relays	87

CURRENT AND VOLTAGE OUTPUTS

Each current channel is rated for 30 A at 200 VA continuous, and can provide 60 A at 300 VA, for short durations. It has a unique flat power curve from 4 to 30 A that insures maximum compliance voltage to load at all times. With only three currents in parallel the unit provides 180 Amperes at 900 VA rms for testing all instantaneous overcurrent relays. With a maximum compliance voltage of 50 Vrms per phase, with just two channels in series provides 100 Vrms of compliance voltage to test high impedance earth fault type relays. Each voltage channel can provide variable outputs of 0 to 300 V at 150 VA of output power, and has a unique flat power curve from 30 to 150 V insuring maximum output power to the load at all times. With three of the voltage channels converted to currents, the unit can provide 9 currents for testing three winding, current differential relays, including harmonic restraint three-phase transformer differential relays, without having to move test leads.

FREJA LOCAL – WITHOUT PC

The most significant feature of the FREJA Local Software is its ability to provide the user with a very simple way to manually test, for both commissioning and maintenance, from the simple overcurrent relay to the most complex relays manufactured today. Manual operation is simplified through the use of a built-in computer operating system and the touch screen. The FREJA Local eliminates the need for a computer when testing virtually all types of relays. Enhanced graphics, intuitive menu screens, and touch screen icon buttons are provided to quickly and easily select the desired test function. The FREJA Local includes non-volatile built-in data storage for saving tests and test results. A USB port is provided for transferring test results by memory stick to your PC.

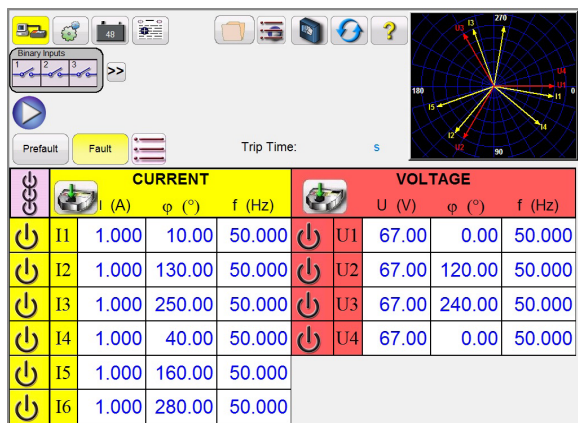

FREJA Local Basic Manual User Interface Screen

Manual Test Screen

In the Manual Test screen the pre-selected outputs are set using the touch screen. Power-up preset default values maybe automatically set from the user defined configuration screen. The user can select from a variety of test options including manual control using the control knob, a dynamic sequence of tests to include trip and reclose operations, an automatic ramp, pulse ramp, or pulse ramp binary search to determine pickup or drop out of relay contacts, or perform relay specific timing tests

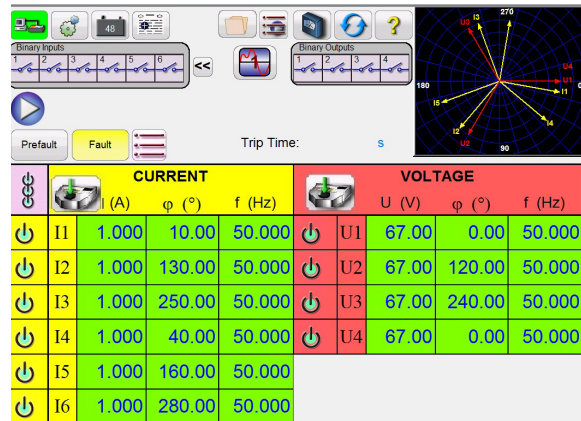

Color Accents when Selected Outputs are on

A vector graph indicates the relative phase angles of all the outputs, or the user can select to see the positive, negative, and zero sequence vectors displayed. The user may select to have all output amplitudes metered to provide real time verification of all of the selected outputs, or have setting values displayed. In the Manual Test Screen the user can set Prefault and Fault values. The user can toggle back and forth between the two values to monitor contact activity. To do a simple timing test the user can set Prefault time duration in seconds, and then press the Blue Play button. The Prefault values will be applied for the Prefault time, then change to the Fault values and start the Timer running. When the relay trips, it will stop the timer, and may turn selected outputs off depending on the user defined Auto-Off configuration. The test results may be saved to the internal memory to download later into a larger database for record keeping.

In the Advanced manual test screen, the user can define up to four waveforms, the default 1 (Fundamental), plus a Second (2), Third (3) and Fourth (4) Waveforms. All four waveforms will be summed together to create a harmonic waveform. This feature is normally used when generating a second, third or fifth harmonics when testing harmonic restraint transformer differential or generator neutral protection relays.

Auto Ramp, Pulse Ramp and Binary Search Features

The FREJA Local Software may be used to automatically determine pickup or dropout of various types of relays. Pressing the Auto Ramp button presents three choices; Step Ramp, Pulse Ramp, and Pulse Ramp Binary Search.



Step Ramp, Pulse Ramp and Pulse Ramp Binary Search Selection Bar

The first selection, Step Ramp, will ramp the output by applying a value and then waiting a specific amount of time before incrementing. For example, to automatically ramp output current the user will select the channel to be ramped, input Start and Stop Amplitudes, an Increment (A), and a Delay time in Cycles (B).

Pulse Ramp will start at user defined prefault condition, increment up or down returning to the prefault condition between each increment. Instead of Delay time the user sets the Pulse Cycles time, which applies the fault value to the relay for the specified time.

The user can select a 2nd, 3rd and 4th ramp if desired, changing the size of the increment with each ramp. This feature is most used when doing instantaneous pickup tests. The output current, or voltage, can be incremented in large steps getting to the pickup point quickly, and then reduce the size of the increment to zero-in on the pickup value. This reduces the test time, heating of the relay under test, and provides a very accurate test result. This feature is also used when testing multi zone distance relays using three phase voltage and currents. Set the Pulse Cycles duration just long enough for the intended zone to operate. If you are not sure exactly where the pickup value of the relay is, you can use the Pulse Ramp Binary Search feature.

Timing Test Feature

Pressing the Time test button on the test menu list, the user is presented a menu of relays to test. Built-in timing tests are provided for a wide variety of protective relays, including Overcurrent, Voltage, and Frequency relays. To make it even easier and faster, the FREJA Local software has ANSI, IEC, and IEEE Standards time curve algorithms built-in. The FREJA Local Software also includes time curves and time curve algorithms for hundreds of specific relays. The user can select from a pull-down list of different manufacturers (over 20 different manufacturers and growing), then select the relay model number, and/or curve shape (inverse, very inverse, definite time etc.). The list includes relay manufacturer's digitized log-log, and semi-log, electromechanical relay time curves. Therefore, tests are conducted using the manufacturer's actual time curve. In the following example, the Schneider MiCOM P123 Standard Inverse relay with a 1 Amp Pickup and a number 2 Time Multiplier was selected.

The screenshot shows the software interface for a timing test. At the top, there are binary input settings and a graph showing a curve. Below the graph is a table with columns for CURRENT and VOLTAGE. The table has 16 rows, each representing a test point. The columns are: I (A), φ (°), f (Hz) for CURRENT; and U (V), φ (°), f (Hz) for VOLTAGE.

CURRENT				VOLTAGE			
I (A)	φ (°)	f (Hz)	U (V)	φ (°)	f (Hz)		
I1	0.000	0.00	50.000	U1	0.00	0.00	50.000
I2	0.000	0.00	50.000	U2	0.00	0.00	50.000
I3	0.000	0.00	50.000	U3	0.00	0.00	50.000
I4	0.000	0.00	50.000	U4	0.00	0.00	50.000
I5	0.000	0.00	50.000				
I6	0.000	0.00	50.000				

Timing Schneider MiCOM P123 Overcurrent Relay

By entering the appropriate values in the setting screen, when the timing test is conducted, the test results will automatically be plotted and compared to the theoretical values from the relay specific time curve that was selected. Up to 8 test points may be selected. If the test Multiple is changed, the appropriate theoretical trip time will change automatically.

View Test Reports

To view the test result, press the Add Results to Report and View button. The user can now enter appropriate information relative to the test in the Test Report header. See the following example report.

The screenshot shows a test report for a Phase A Timing Test. It includes a header with the Megger logo and company information. Below that is a form with fields for Substation, Position, Page, EOPF Location, Date, Asset ID, Job #, Test Equipment Used, and Tested By. There is also a section for Nameplate Data with fields for Manufacturer, O.E., Model, Serial Number, Devices Operated, CT Ratio, PT Ratio, and Instructon Booklet. The main part of the report is a table with columns: Test Multiple, Test Current (A), Operate Time (s), Minimum Time (s), Theoretical Time (s), Maximum Time (s), and Pass/Fail. To the right of the table is a graph showing the test results.

Test Multiple	Test Current (A)	Operate Time (s)	Minimum Time (s)	Theoretical Time (s)	Maximum Time (s)	Pass/Fail
2	4.00	3.860	3.399	3.785	4.177	Pass
4	8.00	2.060	1.778	2.060	2.367	Pass
6	12.00	1.841	1.546	1.828	1.939	Pass
12	24.00	0.250	0.050	0.250	0.463	Pass

Test Report MiCOM P123 IEC Inverse Timing Test

Note that the software automatically compared the Operating Time to the theoretical and made a Pass Fail determination based upon the manufacturer's time curve characteristic. If the recorded test point(s) is out of specification it appears red in color. If it is within specification it will be green in color. This provides excellent visual As Found reporting. If the data is imported into a PC, reports can be generated that summarize the comments and failures of every test you perform for future reporting requirements.

State Sequence Timing Test Feature

Pressing the State Sequence button on the test menu list takes the user to the Sequence Timing Test Screen. There are up to 15 programmable steps available in the Sequencer Test Screen.

The screenshot shows the State Sequence Timing Test Screen. It features a top toolbar with various icons and a central display area. Below the toolbar is a table with columns for CURRENT and VOLTAGE. The table has 16 rows, each representing a test point. The columns are: I (A), φ (°), f (Hz) for CURRENT; and U (V), φ (°), f (Hz) for VOLTAGE.

CURRENT				VOLTAGE			
I (A)	φ (°)	f (Hz)	U (V)	φ (°)	f (Hz)		
I1	1.000	15.00	50.000	U1	67.00	0.00	50.000
I2	1.000	135.00	50.000	U2	67.00	120.00	50.000
I3	1.000	255.00	50.000	U3	67.00	240.00	50.000
I4	0.000	0.00	50.000	U4	0.00	0.00	50.000
I5	0.000	120.00	50.000				
I6	0.000	240.00	50.000				

Multi-State Sequence Test Screen

By default, 9 states are already labeled as Prefault, Trip1, Reclose 1, etc. up to Lockout in step 9. Therefore, it is initially setup for a four shot trip, reclose to lockout scenario. The user is free to change the labels, or use the default labels. With each state the user may input values of voltage, current, phase angle, frequency and set the Binary Input sensing for each state. Both single pole and three pole trip can be simulated. There are default values and binary settings for a single phase trip and reclose scenario already programmed in. The user can either use the defaults or change them to suit the application. The Total Time to Lockout is also included in the setting and indicates where the total timer starts and stops. This allows for 1, 2, 3, or 4 shots to lockout including trip and reclose times. The user can set conditional settings such as Wait IRIG time setting (for End-to-End tests), Wait milliseconds, Wait cycles, Wait any contact (OR), and Wait all contacts (AND). The user can set the Binary Outputs to simulate the breaker 52a and/or 52b contacts.

Once all of the Binary Inputs, Outputs, Prefault, Fault and Reclose settings are completed, the user can then press the Preview button to get a visual representation of the voltage and current outputs, as well as a visual of the binary inputs and outputs for each stage of the simulation. The following figure illustrates a sample sequence.

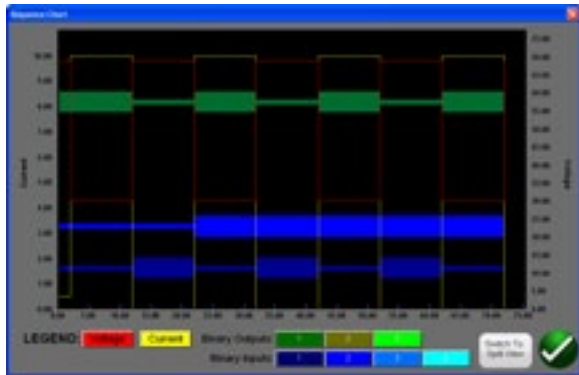

Sample Sequence Voltage, Current, Binary Inputs and Outputs

Impedance Relay Click-On-Fault

The all new Click-On-Fault (COF) is one of the choices in the test menu list. The new COF provides automatic tests of Impedance (distance) relays. It includes Pulse Ramp, Pulse Ramp Binary Search, and Shot test capabilities.

Selection of Relay Operating Characteristics

Select from one the predefined generic relay characteristics of MHO, Half MHO or QUAD (Quadrilateral), or import a RIO file supplied by a number of relay manufacturers, or select from the relay specific Relay Library files. The Relay Library currently includes distance relays from SEL, GE, AREVA, and ABB. There are numerous other library test files which are still being tested and field evaluated. Therefore, as new relay library files become available a new version of the software will be posted to the website for download and field upgrades.

Definition of Operating Characteristic and Tests

There are several new innovations in the new COF that make testing distance relays easier and faster. For example, selecting the Generic QUAD characteristic provides the following user input screen.

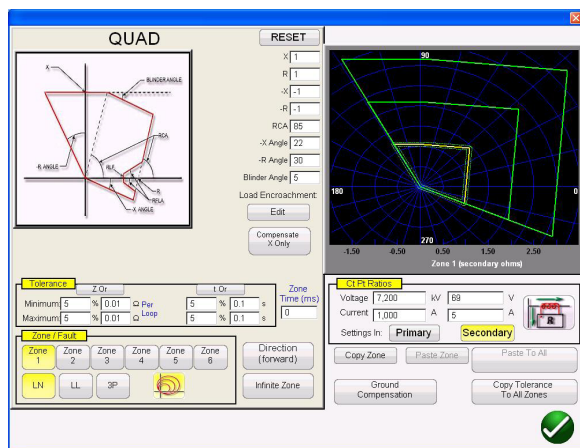

Generic QUAD Setting Screen

Here the user selects which Zone (up to 6 zones may be defined), type of fault, direction, tolerance values, inputs the reach, max torque (line) angle; any offset, or load encroachment settings. For phase to earth faults there are three types of compensation factors to choose from depending on the type of impedance characteristic. The software draws the operating characteristic(s) of the relay defined by the user settings. The user may select to view single zone or multiple zones. Pressing the green check button takes the user to the COF test setup screen, as shown in the following figure.

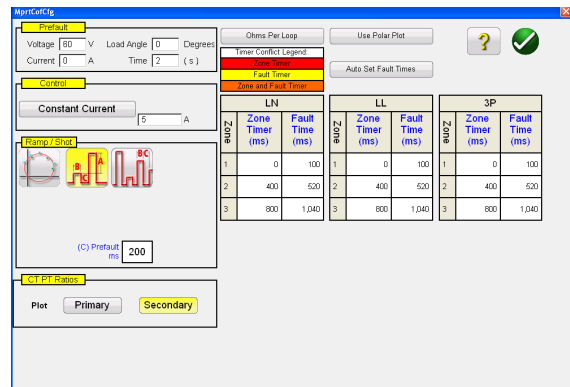

Generic QUAD Test Setup Screen

From this screen the user can select:

Test Method-

- Pulse Ramp
- Pulse Ramp Binary Search
- Shot

Timing of Fault -

- Phase to Ground
- Phase to Phase
- Three Phase

Test Source Models -

- Constant Voltage
- Constant Current
- Constant Source Impedance

Displayed Values -

- Primary Values
- Secondary Values

Creating Search Lines or Shot Test Points

The user can easily define up to 10 search lines or test points per fault type, per zone. Test options include;

The Independence Test option provides maximum freedom to the user to select any test line, at any angle, around the operating characteristic.

The Origin Test option the user clicks a point outside the operating characteristic, and the test line will be drawn to the origin or the intercept of the R and X axis.

The Shots Test Points option is used to create one or more test points, each to replicate a fault at a particular magnitude and angle. This type of test provides a quick GO, NO/GO test of the relay after a settings change.

The user does not even have to draw the test lines. There are two Quick Test Options the user may select. The first option draws three test lines for any of the selected Quick Test solutions. The second Quick Test the user may select the desired number of test points by pressing the Test Points button and select from the list. If none of the standard test points or phase rotations meet s the

user's needs, they can enter the desired values in the window provided.

IEC 60255 Test Option

To comply with regulations which require testing to the IEC 60255 standard, the IEC 60255 option is also provided. All defined test lines will automatically be drawn perpendicular to the relay operating characteristic.

Prefault Settings

For testing relays which require a prefault load condition, the user can set the prefault load voltages and currents. This is normally used when testing accelerated tripping or dynamic over-reach characteristics.

Performing Tests

The user then simply presses the blue Play button and the test begins. To save even more time the user can select the Play All button and the software will automatically test all define zones and faults in sequence. Based upon the user input the software will calculate all of the fault values and angles for each defined test point, and then make PASS/FAIL determination of the test results.

A real-time test screen will display the relay operating characteristic with the defined test lines in the right half of the screen with the test vector moving in the impedance plane, and in the left half it will display either the test vectors of voltage and currents being applied in real-time, or it will display the Positive, Negative and Zero Sequence vectors being applied, see the following example.

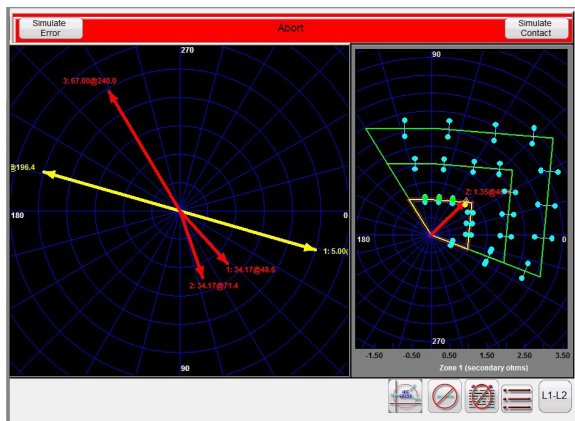

Generic QUAD Real-Time Test Screen

In the above figure a Zone 1, Pulse Ramp, Phase A-B fault is being performed. Note the real-time test amplitudes and angles are displayed in the left half, with the test results displayed in the right half.

Easy Z Impedance Relay Test

The FREJA Local Easy Z provides a quick approach to testing an impedance relay. The following is the Easy Z Impedance Test Screen. All tests are performed from this one screen.

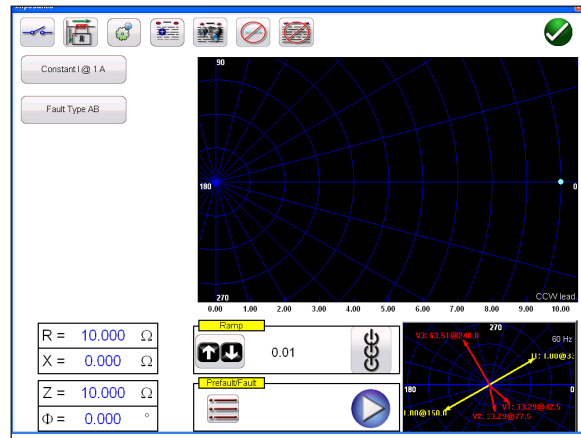

Easy Z Test Screen

CT Polarity Directional button sets the phase angle of the output currents either into or out of the zone.

Constant Source button provides the user with a selection of different methods to perform the tests. Some manufacturers require Constant Voltage and ramp current, some require Constant Current and ramp voltage.

Fault Type selection button provide the user with the Fault Type selection window. The user can select Three Phase Fault, Phase to Phase fault, or Phase to Ground fault. Note there is no ground compensation in the Easy Z test screen. For tests using ground compensation calculations see the Click On Fault test.

In the Ramp selection window the user can ramp outputs in terms of Z, R, X or the angle Phi. The increment of the ramp is also selected in this window. For example, the user desires to ramp impedance Z in 0.01 Ohms as shown above.

New Transformer Differential Test Feature

The all new Transformer Differential Test feature provides automatic tests of three phase Transformer Current Differential relays.

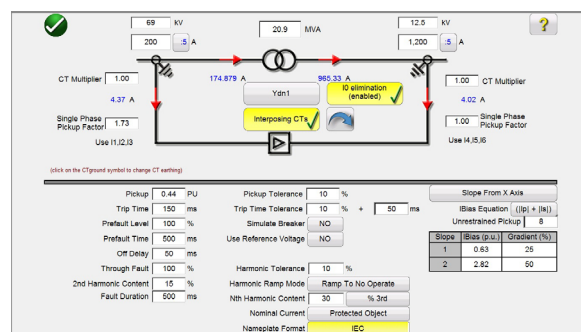

IEC Transformer Differential Model

Transformer Model and Nameplate Settings

There are two transformer differential models to choose from, ANSI and IEC. Each model will present a transformer graphic commonly used either for European or North American style transformer protection. The Transformer Model and Nameplate section includes transformer data, primary and secondary winding configurations, interposing CT's, CT ratios, CT connections, selection of I₀ (zero sequence) elimination, and other relay setting

values and characteristics. From this information the software will automatically calculate what values of current and phase angle relationships get applied to the relay in the tests, thus reducing errors and saving time.

Test selection includes; Stability (Through fault), Pickup, Timing, Slope, Harmonic Block and Harmonic Shot tests.

Definition of Slope Characteristic and Tests

There are several new innovations in the new Transformer Differential Test feature that make testing three phase transformer differential relays easy and fast. For example, the slope characteristics vary by manufacturer design. Four options are provided, which cover the various designs; Line Segments (i.e. G.E. SR 745), Slope Through X Axis (i.e. Siemens 7UT613), Slope Through Origin (i.e. SEL 387 and 587) and Slope From Base Point (i.e. ABB RET670). In addition, different relay manufacturers use different IBias equation methods for restraining the operation of the differential elements. The Transformer Differential Slope test provides seven different biasing (restraint) equations to choose from. For example, the Siemens 7UT5X, 7UT6X and SEL 487 and 787 relays use the biasing equation ($|I_p| + |I_s|$). The user simply touches the screen to create test lines associated with the slope characteristic. The following is an example test being performed with four test lines.

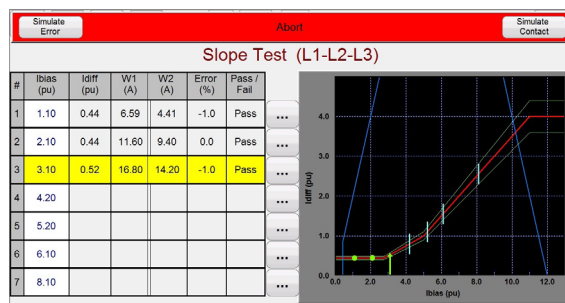

Transformer Differential Slope Test

Note the test amplitudes are displayed in the left half (includes Pass/Fail) with the test results displayed in the right half along with the slope characteristic.

New Synchronizer Test Feature

The all new Synchronizer Test Feature provides automatic tests of synchronizing and sync-check type relays.

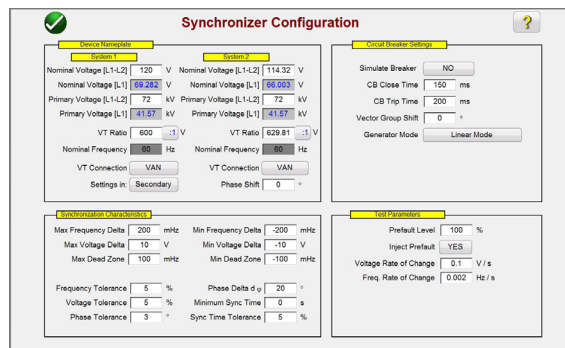

Synchronizing Configuration Screen

In the In the Device Nameplate section the user inputs information associated with System 1 and System 2, which includes Phase – Neutral or Phase - Phase Primary and Secondary voltage information. In the Synchronizing Characteristic section the user inputs the Voltage and Frequency Delta values as well as the tolerance values of the relay under test. In the Circuit Breaker section the user inputs values associated with the Closing and Trip times of the Circuit Breaker for breaker simulation. In the Test Parameters section the user inputs the desired Rate of Change for the Voltage and Frequency changes.

Creating and Performing Tests

There are three options available to the user regarding the selection of test lines. Selection of the Quick Test, the software will automatically draw 4 test lines with two Delta Voltage lines and two Delta Frequency lines. Selection of the Dynamic Points, as shown below, draws eight test lines, with two Delta Voltage, two Delta Frequency, and four Dynamic test lines where both Frequency and Voltage are run in Delta. If either of these two options does not meet the user's needs, the user is free to select their own test points by touching or clicking on the test screen points outside and inside the characteristic similar to the Click-on-Fault for Impedance relays.

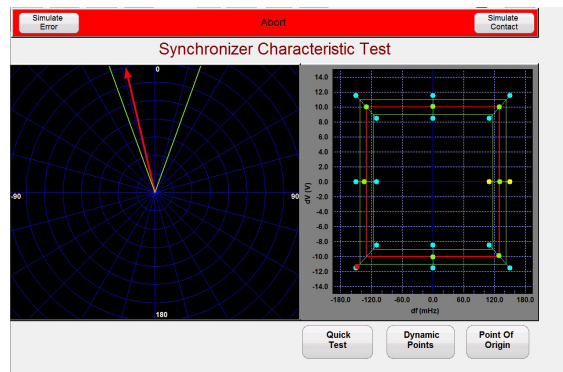

Dynamic Synchronizing Test Screen

In the left side of the test screen the user can observe the synchroscope as the test voltage rotates, while in the right side the user can observe the dynamic test point closing in on the close characteristic for the relay in real time. When the relay close is captured the test results are shown similar to the above where the green dots indicate a passing test result.

FEATURES AND BENEFITS

Top Panel

1. **Current Outputs**- 6 phases (6 x 60 A)
2. **Voltage Outputs**- 4 x 300 V at 150 VA, or 4 convertible channels to current providing 15 A at 120 VA
3. **Binary Inputs 1, 2 and 3** – Rated 5 to 300 V AC/DC
4. **Binary Outputs 1, 2 and 3** – Rated 300 V AC/DC, 8 A
5. **Binary Outputs 5 and 6** – High Speed, 400 V AC/DC peak, 1 Ampere
6. **Binary Output 4** – Rated 300 V AC/DC, 8 A
7. **Binary Inputs 4,5,6,7,8,9,10** - Rated 5 to 300 V AC/DC
8. **DC Supply** – Variable 10 to 250 V DC, 100 Watts/3.33 A
9. **Transducer Input Terminals** – (Optional) Inputs available to measure DC volts or DC milliamps

Front Panel

1. **Mains Inlet Socket** – 100 to 240 V, 50/60 Hz
2. **Protective Earth Terminal**
3. **Power ON/OFF Switch** – Illuminates when power is on
4. **Isolated Ethernet Port** – For connecting to IEC 61850 Substation Bus
5. **PC / IN Ethernet Port** – Primary PC connection Port for automated testing. Also used when chaining to other FREJA units for multi-phase testing.
6. **IEC 61850 / OUT Port** – Used when testing IEC 61850 devices. Also used to chain to other FREJA units for multi-phase testing.
7. **USB Ports** - Two type A ports available. This port is used to update the firmware and software in the FREJA unit. It may also be used to download test results from the FREJA for download into a PC for storage or printing.
8. **USB (TO PC) Interface** – The (TO PC) USB Interface requires a Type B “downstream” connector, and is a communication and control port when used with a PC and Megger software for automated relay testing.
9. **Local HMI** – TFT LCD, full color touch screen.
10. **Control Knob**

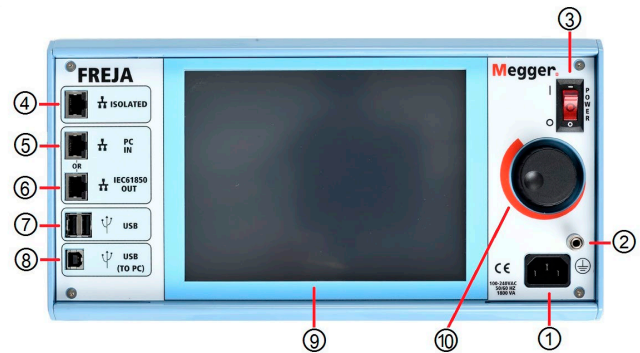
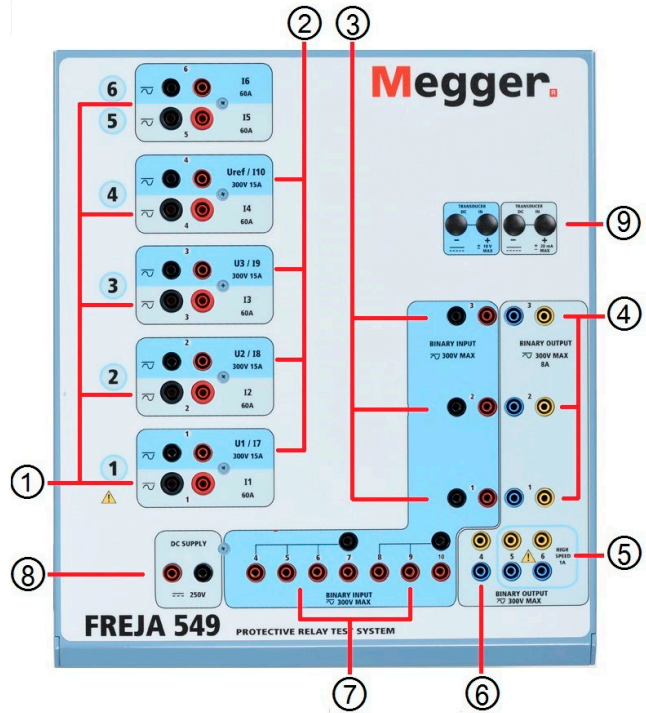

	# Current Generators	# Voltage	Operating Modes
FREJA 549	6 (9)*	4*	4 Voltages (4 x 300 Volts) 6 Currents (6 x 60 Amps)
			4 Voltages (4 x 300 Volts) 3 Currents (3 x 120 A)
			4 Voltages (4 x 300 Volts) 1 Current (360 Amps)
			1 Voltage (1 x 300 Volts) 9 Currents (6 x 60 A + 3 x 15 A*)

* Configurable convertible voltage channels with HMI

Megger.

FREJA WIN

In FREJA™ Win, the all-round General instrument program serves as a convenient, easy to understand, user-friendly toolbox. On the Connect page, you can enter information about how to connect the relay, including pictures if so desired.

On the Sequence page, you can vary all generator parameters independently. You can have up to 25 different states (prefault, fault1, prefault, fault2, prefault, fault3 etc.). This is useful when testing auto-reclose relays or motor protection. It's also possible to generate up to the 25th harmonic.

On the Ramp page, you can ramp all generator parameters independently. Amplitudes and angles are shown on a vector diagram, and values can be set using the knob on FREJA or the PC keyboard and mouse, on-line as well.

Distance instrument

Configuration page

The Distance instrument program is designed to test distance relays. On the Configuration page, you enter the number of zones that are to be tested and also the time and impedance tolerances, thereby creating an automatic test. No programming is needed. Later, when you recall this object via the Control center, all settings are re-established so that you can start testing immediately.

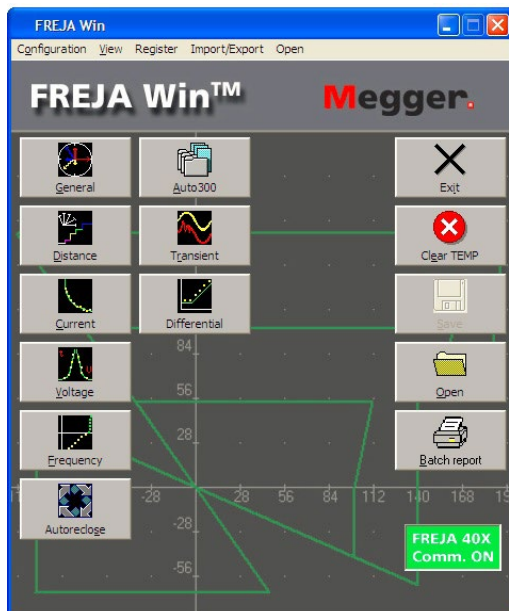

Control Center

Connect page

On the Connect page you enter information about how to make connections to the relay, including pictures if so desired. Since this information is saved together with the object in the Control center, it can be displayed again the next time you want to test this relay.

Zt page

The Zt page is designed for time testing of a distance relay. Normally, you test one type of fault at a time when testing relays. With FREJA Win, however, you can test all seven fault types automatically if so desired. All you have to do is press the <Start> button. FREJA will test all seven fault types automatically and then compare the readings with the theoretical values that you entered

on the Configuration page. If the readings are OK, a green lamp lights. If not, a red lamp lights. If you want to check the reverse direction, the test can start below zero ohms in the 3rd quadrant.

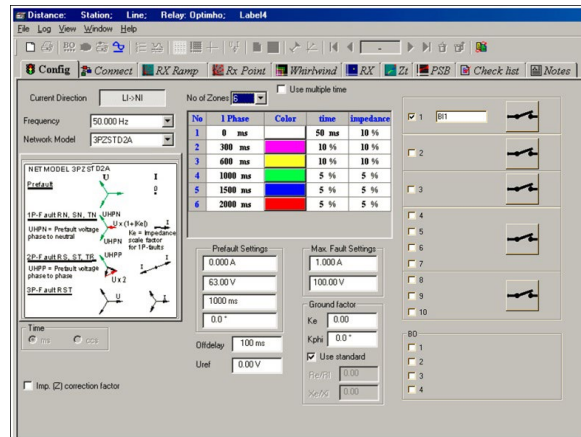

Distance, Configuration

RX-ramp page

The RX-ramp page, which is part of the Distance instrument program, is designed to test the reach of a distance relay. First, you define the start and stop angles and the delta phi between the ramps. Then press the <Start> button and relax. FREJA will automatically test all seven types of faults using the time saving "search-half" method. You can also define your own ramps, using the mouse to specify starting and ending points wherever desired. If you have defined a theoretical reference graph, the program will compare the actual test result with your graph and check for any deviations from the tolerances entered on the Configuration page. If the results are OK, a green lamp lights, if not, a red lamp lights.

RX page

The RX page enables you to define test points manually. You can define different points on the oscilloscope using the mouse or keyboard. Select the automatic mode and press the <Start> button. FREJA will test all points for the selected fault types. The points will be assigned different colors, depending on the trip time. If you select the manual mode, you can use the dial to search for a boundary.

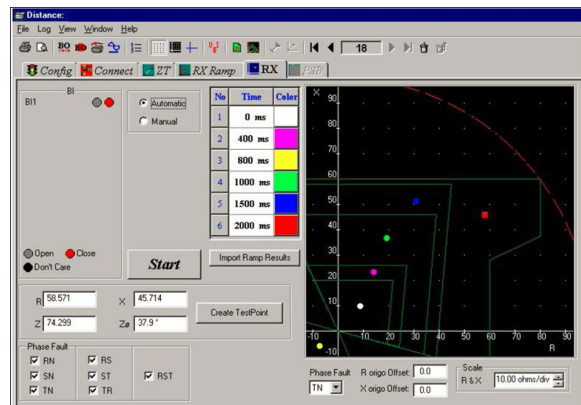

Distance, Rx

Reference graphs

Efficient testing and performance analysis require well-defined reference values. FREJA can automatically create the IEC and IEEE® standard curves for overcurrent relays. It is also possible to create reference graphs in the impedance plane using the

included library of distance relays made by major manufacturers and/or create other characteristics using the standard circular lens and linear elements (including mho, quadrilateral and ice-cream cone shapes). The cut and paste buttons make it easy to take copies of the first zone and then edit these copies by inserting zone 2 and zone 3 values.

Some relay manufacturers can create a RIO-file with the settings of the relay. Using the FREJA RIO-converter you can create reference graphs based on these settings.

A feature is the ready-made current curves available for many relay types.

Current instrument

The Current testing instrument is designed to test all types of current relays, from electro-mechanic with or without an induction disc to modern numerical relays.

The Config page is where the relay settings will be entered.

In the Pick-up page the system will not just get the pick-up value (start current) but also the drop out and it will also calculate automatically the hysteresis.

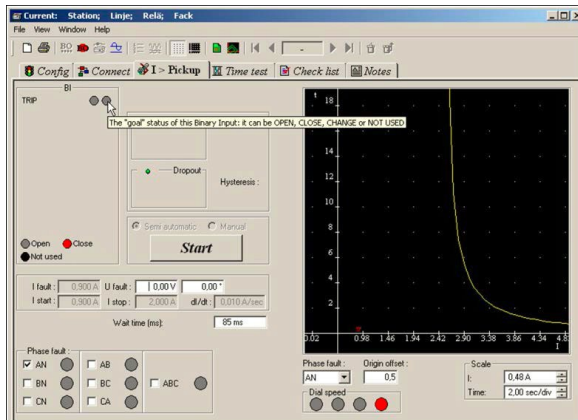

Current Instrument, Pick-up

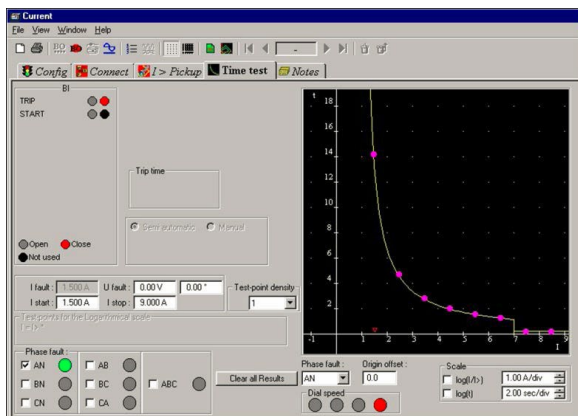

Current Instrument, Time test

Voltage instrument

The Voltage testing instrument is designed to test all types of voltage relays, from electro-mechanic to modern numerical relays.

The Config page is where the relay settings will be entered.

In the Pick-up page the system will not just get the pick-up value (start voltage) but also the drop out and the hysteresis will be calculate automatically.

The time test, check the trip time at different voltage values, will be done in the Time Test page. A reference curve can be created in the same way as in Distance, by choosing the corresponding time curve and entering the settings. The time test can be run also in a logarithmic scale, time, current or both.

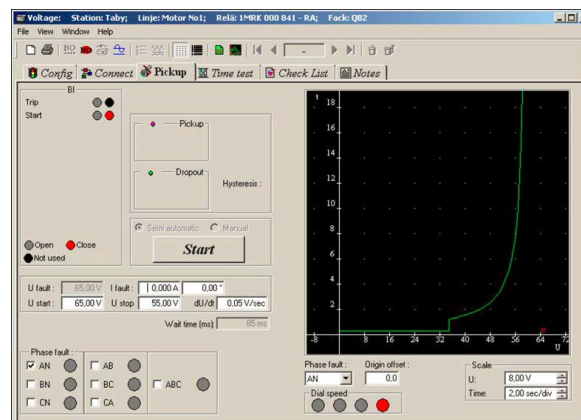

Voltage instrument, Pick-up

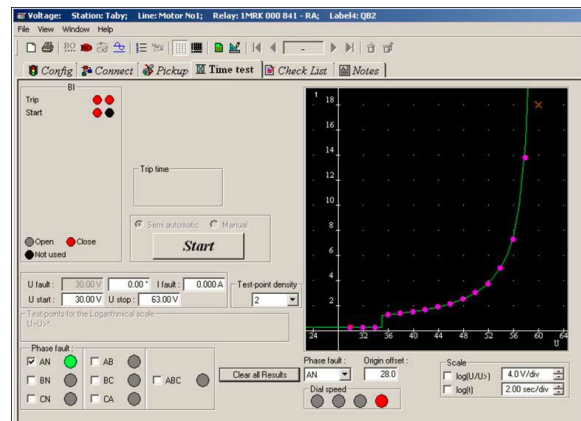

Voltage instrument, Time test

Frequency instrument

In the Frequency instrument a pre-fault and fault frequency can be generated manually in Manual page as well as an automatic sequence of pre-fault, fault, from a set start value to set stop value to Scan the trip time at different frequency values, useful for relays with two stages.

The Ramp mode will find the set fault frequency.

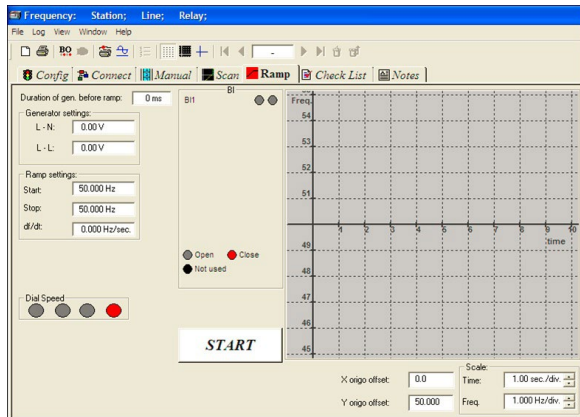

Frequency Instrument, Ramp

Auto-reclose instrument

The Auto-reclose instrument is a combination between Sequence in General and RX in Distance. This is just because it is easier to simulate pre-fault, energizing and dead times as vectors and in the same way it is easier to simulate a fault in an impedance plane. This instrument will test any auto-recloser function on today's modern relays.

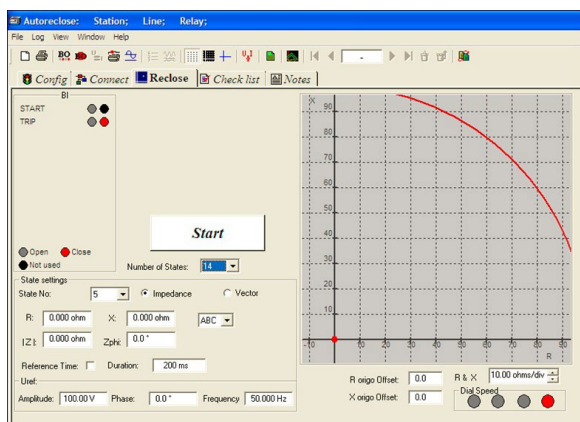

Autoreclose instrument

Auto 300

If we take as an example a modern distance relays has several functions activated, besides the distance elements.

By using Auto 300 we can link together different tests made in different instruments, to create an automatic test sequence, so at the end we will have on test containing elements from Distance, Current, Sync and Voltage, for example.

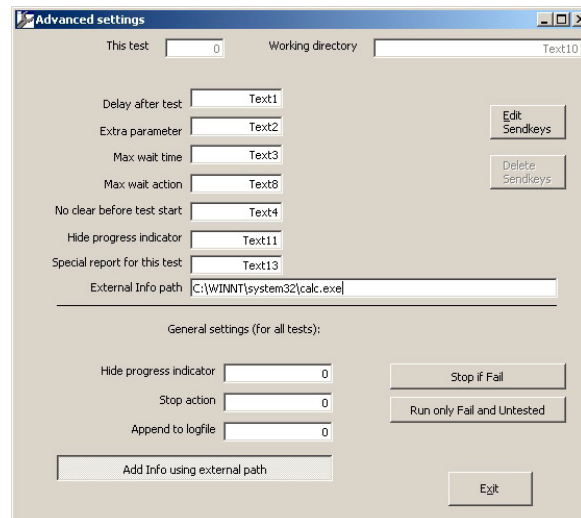

Auto 300

Transient instrument

With the help of Transient, FREJA will generate (playback) a waveform recorded by a disturbance recorder. The file formats supported by Transient are COMTRADE, ASCII, EMTP WAX, EMTP PC and Inductic 65.

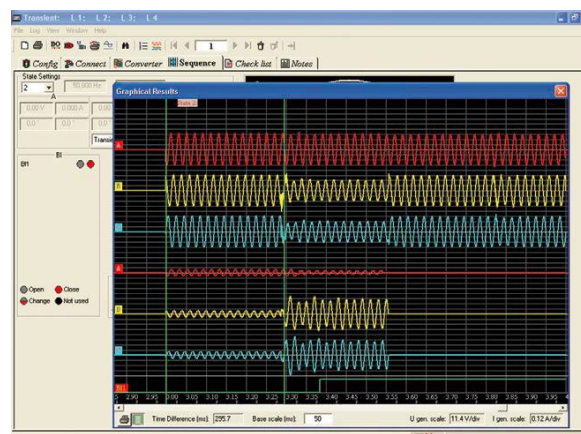

Transient instrument

Differential instrument

The Differential instrument is designed to test transformer protection relays and works with FREJA 549, as it makes use of 6 current generators.

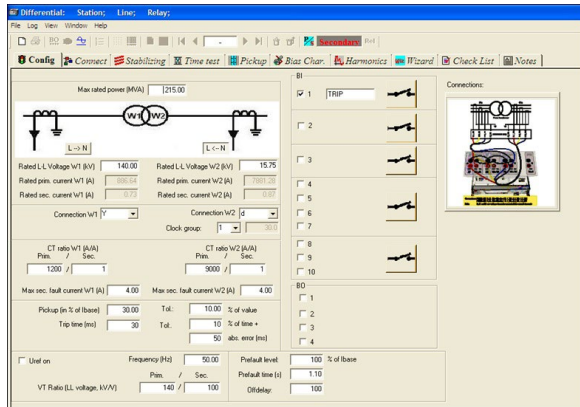

Differential instrument

It can be used to test multi winding transformer protection relays, by testing a pair of windings at a time.

FREJA Differential can also be used to test differential generator protection relays and line differential protection relays. The data for the protected power transformer are entered in a very intuitive way that cannot be misunderstood by the user. This is done by using buttons and icons that immediately show to the user the effect of his choices. The injected currents are shown both in primary and secondary values, depending on the entered current transformers information and star point earthing.

The Stabilizing page has the purpose of verifying that the connections and settings in FREJA are correct by generating external faults and verifying that the relay is stable. The operator is also requested to read the measured values by the relay and enter them in the test page. The values will then be reported in the final report.

The Time Test page allows to verify the operate time of the differential relay. Several fault injections can be programmed and the page reports the statistics of the measured operate times (minimum, maximum and average values).

The Pick-up page allows the test of the minimum operating current of the differential relay for each winding, which is a test on the sensitivity of the relay. This test also makes use of pseudo-continuous ramp injections.

In the page Bias Characteristic it is possible to test the operating relay characteristic by running pseudo-continuous ramps (for testing the static accuracy of the relay) or ramps done by sequences of prefault and fault steady state simulations, called as "binary search", more suitable for commissioning tests. The characteristic can be tested with or without making use of the reference graph.

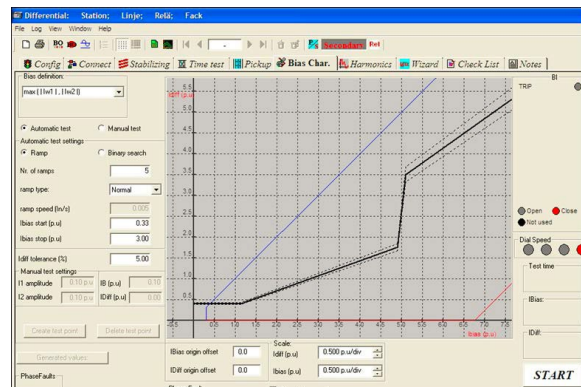

Differential Instrument, Bias Characteristic

The Harmonics page verifies the relay capability of not issuing the trip signal for faults in the trip area of the restrained characteristic, when a certain level of harmonics is present in the fault currents, for each winding of the power transformer. The purpose of this feature is to keep the relay stable during transformer energising or during transformer overexcitation.

A very important test, introduced by Programma for the first time, is called Wizard. It will help discovering wrong settings for the differential transformer relays that might cause unwanted trip for external ground faults.

The Wizard will ask important and clear application questions to the relay engineer and will perform some simple tests on the relay in a semi-automatic manner. Depending on the application information entered by the user, the Wizard will report if the relay seems to be correctly set or not with a clear information to the user.

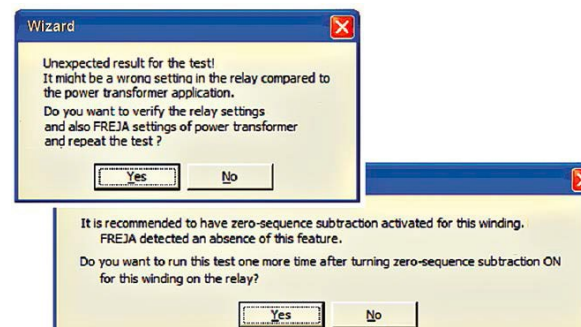

Differential Instrument, Wizard

IEC 61850 GOOSE

The FREJA with the GOOSE enabled, in conjunction with the Megger GOOSE Configurator (MGC) software, can be used in the testing or commissioning of IEC 61850 compliant devices.

SPECIFICATIONS

Specifications are valid for resistive load, nominal voltage supply and ambient temperature +25°C ±3°C, (77°F ±5.4°F) after 30 minutes warm up time. All hardware data are for full scale values. Specifications are subject to change without notice.

Environment

Application field	For use in high-voltage substations and industrial environments.
Temperature	
Operating	0°C to +50°C (32°F to +122°F)
Storage & transport	-25°C to +70°C (-13°F to +158°F)
Humidity	5% – 90% RH, non-condensing
Altitude (operational)	3000 m Full duty cycle up to 2000 m. Duty cycle limitation based on internal over temperature protection for altitudes >2000 m.

CE-marking

EMC	EN 61326:2006
LVD	EN/IEC 61010-1:2001 (Second Edition)

Conformance Standards

Shock	EN/IEC 60068-2-27
Vibration	EN/IEC 68-2-6
Transit Drop	ISTA 1A
Free Fall	EN/IEC 60068-2-32
Drop / Topple	EN/IEC 60068-2-31

General

Mains input	100 - 240 Volts AC, 50/60 Hz
Power consumption	1800 VA
Dimensions	337 W x 172 H x 381 D mm 13.25 W x 6.75 H x 15 D in.
Weight	19.2 kg (42.65 lb.)
Display	TFT LCD Touch Screen
Available	
Languages	English, French, German, Spanish
Communication	
Interfaces	(3) Ethernet Ports (2) USB "A" Ports (1) USB "B" Port Bluetooth

Measurement Section

Measured output quantities such as AC Amperes, AC Volts, DC Volts or DC Amperes, and Time may be simultaneously displayed on the touch screen. Preset AC and DC outputs display the approximate voltage/current output prior to initiation. This provides a fast, easy method for preset of outputs. Other values that may be displayed, depending on which test screen is in view, are phase angle, frequency, Ohms, Watts, VA, and Power Factor. All Accuracies stated are from 10 to 100% of the range at 50/60 Hz.

AC Voltage Amplitude

Accuracy:	±0.05 % reading + 0.02 % range typical, ±0.15 % reading + 0.05 % range maximum
Resolution:	0.01
Measurements:	AC RMS
Ranges:	30, 150, 300V

AC Current Amplitude

Accuracy:	±0.05 % reading + 0.02 % range typical, ±0.15 % reading + 0.05 % range maximum
Resolution:	0.001/0.01
Measurements:	AC RMS
Ranges:	30, 60A

DC Voltage Amplitude

Accuracy:	0.1% range typical, 0.25% range maximum
Resolution:	0.01
Measurements:	RMS
Ranges:	30, 150, 300V

DC Current Amplitude

Accuracy:	±0.05 % reading + 0.02 % range typical, ±0.15 % reading + 0.05 % range maximum
Resolution:	0.001/0.01
Measurements:	RMS
Ranges:	30A

Convertible Source in AC Current Mode

Accuracy:	±0.05 % reading + 0.02 % range typical, ±0.15 % reading + 0.05 % range or ±12.5 mA whichever is greater
Resolution:	0.001
Measurements:	AC RMS
Ranges:	5, 15A

Phase Angle

Ranges: 0.00 to 359.99 degrees, Counter Clock Wise, or Clock
Wise rotation, or 0.00 to ±180.00 degrees
Accuracy: ±0.02° typical, ±0.25° max at 50/60 Hz

Frequency

The output modules provide a variable frequency output with the following ranges and accuracy.
Ranges
DC
0.001 to 1000.000 Hz
Output amplifiers can provide transient signals with a range of
DC to 10 kHz for transient playback using COMTRADE files.
Resolution*: .0001/.001 Hz
Frequency Accuracy:
2.5 ppm typical
25 ppm 0° to 50° C, at 50/60 Hz

DC IN Inputs (Optional Transducer Feature)

DC IN Volts

Range:	0 to ±10 V DC
Accuracy:	±0.001% reading + 0.005% range Typical ±0.003% reading + 0.02% range Max
Resolution:	0.001
Measurements:	Average

DC IN Amperes

Range: 0 to ± 1 mA DC 4 to ± 20 mA DC
 Accuracy: $\pm 0.001\%$ reading + 0.005% range
 Typical $\pm 0.003\%$ reading + 0.02% range Max
 Resolution: 0.001
 Measurements: Average

Timer

The Timer-Monitor Input is designed to monitor and time-tag inputs, like a sequence of events recorder. In addition, the binary input controls enable the user to perform logic AND/OR functions, and conditionally control the binary output relay to simulate circuit breaker, trip, reclose and carrier control operation in real-time. The Timer function displays in Seconds or Cycles, with the following range and resolution:

Seconds: 0.0001 to 99999.9 (Auto Ranging)
 Cycles: 0.01 to 99999.9 (Auto Ranging)
 Accuracy: $\pm 0.001\%$ of reading, typical. ± 2 least significant digit, $\pm 0.005\%$ of reading from 0 to 50° C maximum

Binary Inputs – Start/Stop/Monitor gate

To monitor operation of relay contacts or trip SCR, continuity light is provided for the input gate. Upon sensing continuity the lamp will glow. In addition to serving as wet/dry contacts the Binary Inputs may be programmed to trigger binary output sequence(s).
 Input Rating: up to 300 V AC/DC

Binary Output Relays

Independent, galvanically isolated, output relay contacts to accurately simulate relay or power system inputs to completely test relays removed from the power system. The binary output simulates normally open, or normally closed, contacts for testing breaker failure schemes. The binary output can be configured to change state based on binary input logic.

High Current Output Relays 1 to 4:

AC Rating: 400 V max., I_{max}: 8 Amps, 2000 VA max.
 DC Rating: 300 V max., I_{max}: 8 Amps, 80 W
 Response Time: <10ms

High Speed Output Relays 5 and 6:

AC/DC Rating: 400 V peak, I_{max}: 1 amp
 Response Time: <1ms typical

GENERATION SECTION

All outputs are independent from sudden changes in line voltage and frequency. All outputs are regulated so changes in load impedance do not affect the output. Each output module consists of one voltage amplifier, and a current amplifier. The voltage amplifier may be converted to a current source. Therefore, one amplifier module may be used to test single phase current differential relays, including harmonic restraint.

Output Current Sources

The FREJA 549 can provide six current sources 0 – 30 Amps continuous, with a max output current of 60 Amps at 300 VA for 1.5 seconds. In addition the unit can provide up to nine current sources; six high current/high power, and three convertible voltage channels providing lower current/high power. The per channel output current and power ratings are specified in AC rms values and peak power ratings.

Per Channel Output

Output (AC)	Power	Max V
1 Ampere	15 VA	15.0 Vrms
4 Amperes	200 VA (282 peak)	50.0 Vrms
15 Amperes	200 VA (282 peak)	13.4 Vrms
30 Amperes	200 VA (282 peak)	6.67 Vrms
60 Amperes	300 VA (424 peak)	5.00 Vrms

Output (DC)

0 – 30 A 200 Watts

Duty Cycle: 30 Amps Continuous, 60 Amps 1.5 seconds

Three Currents in Parallel:

Output Current	Power	Max V
12 Amperes	600 VA (848 peak)	50.0 Vrms
50 Amperes	600 VA (848 peak)	13.4 Vrms
90 Amperes	600 VA (848 peak)	6.67 Vrms
180 Amperes	900 VA (1272 peak)	5.00 Vrms

Four Currents in Parallel:

Output Current	Power	Max V
16 Amperes	800 VA (1132 peak)	50.0 Vrms
60 Amperes	800 VA (1132 peak)	13.4 Vrms
120 Amperes	800 VA (1132 peak)	6.67 Vrms
240 Amperes	1200 VA (1697 peak)	5.00 Vrms

Two Currents in Series

With two currents in series, the compliance voltage doubles to provide 4.0 Amperes at 100 Vrms.

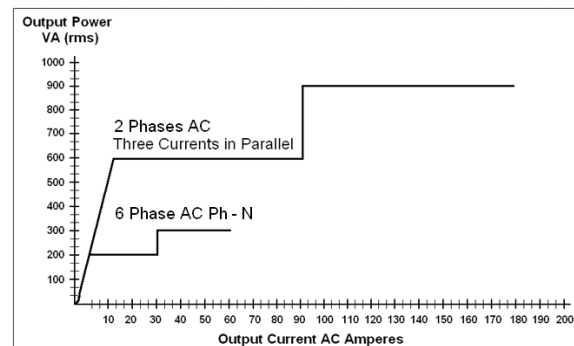

Current Output Power Curve for FREJA 549

Current Amplifier - Extended Power Range

The FREJA 500-SERIES current amplifier provides a unique flat power curve from 4 to 30 Amperes per phase to provide testing of electromechanical high impedance relays, and other high burden applications.

Voltage Outputs

Outputs are rated with the following Ranges:

Range (AC)	Power	Max I
30 Volts	150 VA	5 A
150 Volts	150 VA	Variable
300 Volts	150 VA	0.5 A

Range (DC)

0 – 300 V 150 Watts

Duty Cycle: Continuous

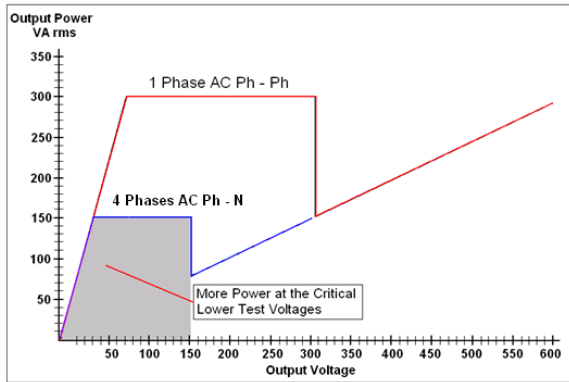

Voltage Output Power Curve

“PowerV[®]” Voltage Amplifier-Extended Power Range

The FREJA 500-SERIES voltage amplifier provides a flat power curve from 30 to 150 Volts in the 150V range to permit testing of high current applications such as panel testing, and older electro-mechanical distance relays which demand a higher power voltage source to properly test.

FREJA 549 Voltage Amplifier in Current Mode:

The FREJA 549 voltage amplifier is convertible to a current source with the following output capability. Output power ratings are specified in AC rms values and peak power ratings.

<u>Output Current</u>	<u>Power</u>	<u>Max V</u>
5 Amperes	150 VA (212 peak)	30.0 Vrms
15 Amperes	120 VA	8.0 Vrms

Duty Cycle: 5 Amps Continuous, 15 Amps 1.5 seconds

DC Supply

The FREJA 549 unit includes a battery simulator with a continuously variable DC output voltage ranging from 10 to 250 Volts at 100 Watts, 3.33 Amps max, providing capability to power up relays with redundant power supplies. Voltage output is controlled via the FREJA Local software and front panel control knob, or through FREJA WIN software.

Total Harmonic Distortion

Less than 0.1% typical, 2% maximum at 50/60 Hz

Waveform Storage

Each output channel can store waveforms for playback on command. End-to-end playback of stored waveforms is possible, when triggered externally by a GPS receiver. Each channel can store up to 256,000 samples.

Protection

Voltage outputs are protected from short circuits and prolonged overloads. Current outputs are protected against open circuits and overloads.

Enclosure and Transit Cases

The unit comes mounted in a robust metal enclosure for field portability. Optional soft-sided and hard-sided transit cases are available. The soft-sided case has approximately 2.5 cm of padding, which provides moderate protection against rain, dust, vibration and shock. The robust design of the optional hard-sided transit case provides protection when transporting the unit over rugged terrain and long distances.

¹ PowerV[™] voltage amplifier output current varies depending on the voltage setting on the 150 Volt range, see curve.

FREJA500 SERIES ORDERING INFORMATION STYLE NUMBER

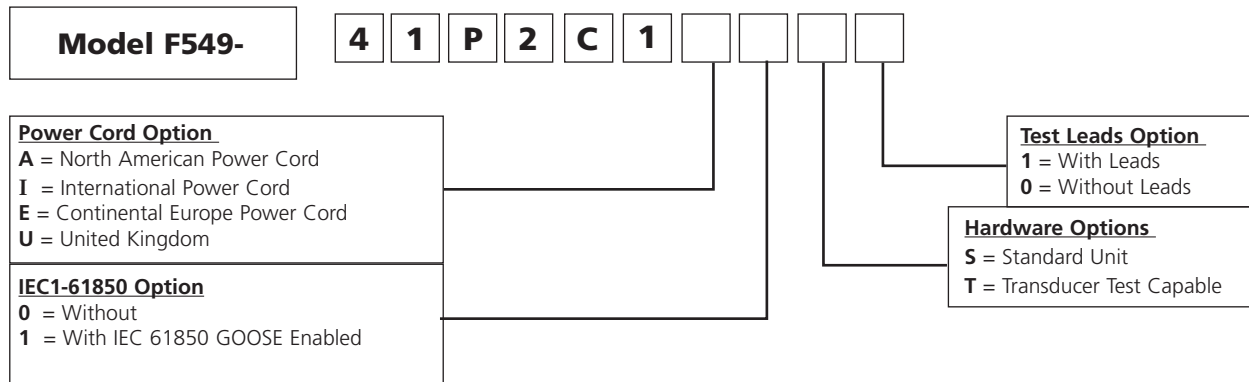

Descriptions of Standard Features and Options

The **FREJA 549** is an advanced multi-phase relay testing system. The system consists of 4 Voltage channels providing 0 – 300 Volts AC, which can be converted to Current channels providing 0 – 5 Amps continuous, and up to 15 Amps for short durations. It also includes 6 Current channels providing 0 – 30 Amperes continuously, and up to 60 Amperes for short durations. All output channels are floating common returns. The unit includes 10 binary inputs and 6 binary outputs. The built-in FREJA Local Touch View Screen interface provides manual and automated control of the unit without the need of a PC and software. For more automated control and IEC 61850 testing, the unit comes with three Ethernet ports, two USB type B ports, one USB type A port, and a Bluetooth wireless interface as built-in standard features .

Options

Power Cord Option - Customers can choose which type of power cord they want the unit to come with.

- **A** option – NEMA 5-15 to IEC60320 C13 connectors, UL & CSA approved for countries with NEMA outlets.
- **I** option - International color coded wires (light blue, brown and green with yellow stripe) insulation jacket stripped ready for male connector with IEC 60320 C13 connector, CE marked.
- **E** option - CEE 7/7 “Schuko” plug to IEC 60320 C13 connector, CE marked.
- **U** option – United Kingdom power cord with IEC 60320 C13 connector, and 13 Amp fuse. BS 1363 / CE Marked.

IEC 61850 Option: The FREJA 549, in conjunction with the optional Megger GOOSE Configurator (MGC) software, can be used in the testing or commissioning of IEC 61850 compliant devices. In order for the FREJA 549 to be able to subscribe as well as publish GOOSE messages, the IEC 61850 feature needs to be enabled. Enter the number 1 for the unit to come with the IEC 61850 option enabled. Enter 0 for the unit without IEC 61850 enabled.

Hardware Options: S= Standard unit. T= With Transducer test capability enabled.

Test Leads Option: Enter the number 1 for the unit to come with Test Leads. Enter 0 for the unit without Test Leads.

Popular Configurations

Some popular FREJA 549 configurations with the International Power Cord option are in the following table. For units with other power cord options, substitute the letter I with the appropriate letter selection.

Style Number	Description
F549-41P2C1I1T1	FREJA 549 Standalone: Includes: International power cord, with IEC 61850 test capability, test leads and transducer test capability
F549-41P2C1I1S1	FREJA 549 Standalone: Includes: International power cord, with IEC 61850 test capability, and test leads. Excludes: No transducer test capability
F549-41P2C1I0T1	FREJA 549 Standalone: Includes: International power cord, Transducer test capability, and test leads. Excludes: no IEC 61850 test capability
F549-41P2C1I0S1	FREJA 549 Standalone: Includes: International power cord, and test leads. Excludes: no IEC 61850 test capability, no transducer test capability
F549-41P2C1I0T0	FREJA 549 Standalone: Includes: International power cord and Transducer test capability. Excludes: no IEC 61850 test capability, no test leads
F549-41P2C1I1S0	FREJA 549 Standalone: Includes: International power cord, with IEC 61850 test capability. Excludes: No transducer test capability, no test leads
F549-41P2C1I0S0	FREJA 549 Standalone: Includes: International power cord. Excludes: no IEC 61850 test capability, no transducer test capability, no test leads

Description of Software Options	Part Numbers
Included Software – Every unit comes with the PC version of the FREJA Local software called FREJA Remote.	84835
Optional Software	
IEC 61850 Megger GOOSE Configurator (MGC)	1007-246
FREJA Win	84673

Included Standard Accessories

Description	Part Number
Power Cord - Depending on the style number, the unit will come with one of the following,	
Line cord, NEMA	90015-267
Line cord, Continental Europe with CEE 7/7 Schuko Plug.....	90015-268
Line cord, International color coded wire.....	90015-269
Line cord, United Kingdom	90015-270
Ethernet cable for interconnection to PC, 210cm (7 ft.) long (Qty. 1 ea.)	90003-684
Instruction manual (digital copy).....	84624



Test Leads and Accessories (Test Leads Option)

The following quantities of Test Leads and Accessories are supplied with the selection of the Test Leads Option. Test Leads and Accessories can be ordered individually, see part numbers and descriptions below.

Descriptions of Optional Test Leads and Accessories	
	<p>Accessory Carry Case: Use to carry power cord, Ethernet cable, Optional test leads and accessories.</p> <p>Qty. 1 ea., Part No. 2003-725</p>
	<p>Sleeved Pair of Test Leads: Sleeved Test Leads, one red, one black, 200 cm (78.7") long, 600 V, 32 Amperes CAT II.</p> <p>Qty. 7 pr., Part No. 2001-394</p>
	<p>Cable / Spade Lug Adapter (Small): Small lug fit most new relay small terminal blocks. Lug adapter, red, 4.1 mm, rated up to 1000 V/ 20 Amps CAT II.</p> <p>Qty. 17 ea., Part No. 684004</p>
	<p>Lug adapter, black, 4.1 mm, rated up to 1000 V/ 20 Amps CAT II</p> <p>Qty. 17 ea., Part Number 684005</p>
	<p>Jumper Lead: Jumper lead, black, 12.5 cm (5") long, use with voltage / current outputs, 600 V, 32 Amperes CAT II.</p> <p>Qty. 6 ea., Part Number 2001-573</p>
	<p>Sleeved Combination Voltage Test Leads: Three common leads connect to the test set, which are interconnected to one black common to connect to the relay. Sleeved, three red and black, 200 cm (78.7") long, 600 V, 32 Amperes CAT II.</p> <p>Qty. 1 ea., Part Number 2001-395</p>
	<p>Sleeved Combination Current Test Leads: Three pairs of leads connect to the test set, and to the relay under test. Sleeved, three red and black, 200 cm (78.7") long, 600 V, 32 Amperes CAT II.</p> <p>Qty. 1 ea., Part Number 2001-396</p>





Test Leads and Accessories (Transducer Option)

The following quantities of Test Leads and Accessories are supplied with the selection of the Transducer Option. Test Leads and Accessories can be ordered individually, see part numbers and descriptions below.









Descriptions of Optional Test Leads and Accessories	
	<p>Sleeved Pair of Test Leads: Sleeved Test Leads, one red, one black, 200 cm (78.7") long, 600 V, 32 Amperes CAT II.</p> <p>Qty. 2 pr., Part No. 2001-394</p>
	<p>Cable / Spade Lug Adapter (Small): Small lug fit most new relay small terminal blocks. Lug adapter, red, 4.1 mm, rated up to 1000 V/ 20 Amps CAT II Qty. 2 ea., Part No. 684004</p> <p>Lug adapter, black, 4.1 mm, rated up to 1000 V/ 20 Amps CAT II Qty. 2 ea., Part Number 684005</p>

Additional Optional Accessories (Not Included in the FREJA 500-SERIES Optional Test Lead and Accessories) - Additional Optional Test Leads and Accessories can be ordered individually, see description and part numbers below. The following accessories and part numbers are in quantities of 1 each. Order the appropriate number as required.

Description

	<p>Individual (Non-Sleeved) Test Leads: Excellent for separated individual terminal test connections.</p> <p>Test Lead, red, use with voltage/current output, or binary I/O, 200 cm long (78.7") 600 V/ 32 Amps CAT II..... 620143</p> <p>Test Lead, black, use with voltage/current output, or binary I/O, 200 cm long (78.7") 600 V/ 32 Amps CAT II..... 620144</p>
	<p>Extra-Long Individual (Non-Sleeved) Test Leads: Excellent for widely separated individual terminal test connections.</p> <p>Test Lead, red, use with voltage/current output, or binary I/O, 360 cm long (144") 600 V/ 32 Amps CAT II..... 2003-173</p> <p>Test Lead, black, use with voltage/current output, or binary I/O, 360 cm long (144") 600 V/ 32 Amps CAT II..... 2003-174</p>
	<p>Jumper Lead: Used to common returns together externally when paralleling current channels (not required when using the sleeved combination current leads 2001-396).</p> <p>Jumper lead, black, 12.5 cm (5") long, use with voltage / current outputs, 600 V, 32 Amps CAT II 2001-573</p>
	<p>Flexible Test Lead Adapter: Use with rail-mounted terminals or screw clamp connections where spade lugs and crocodile/alligator clips cannot be used.</p> <p>Flexible test lead adapter, black, 1.8 mm male pin, use with test leads up to 1000 V/ 32 Amps CAT III..... 90001-845</p>

Additional Optional Accessories (Not Included in the FREJA 500-SERIES Optional Test Lead and Accessories) Continued:

	<p>Flexible Test Lead Adapter with Retractable Insulated Sleeve: Use for connection to old style non-safety sockets with retractable protective sleeve on one end.</p> <p>Retractable Sleeve Test Lead, red, 50 cm (20") long, use with test leads up to 600 V, 32 Amperes CAT II90001-843</p> <p>Retractable Sleeve Test Lead, black, 50 cm (20") long, use with test leads up to 600 V, 32 Amperes CAT II90001-844</p>
	<p>In-Line Fused Test Lead: Use with high speed binary outputs 5 or 6 to protect for accidental switching of currents higher than 1 Amp.</p> <p>Test lead, blue, in-line 500 mA fuse protection, 200 cm long (78.7")568026</p>
	<p>In-Line Fused Test Lead: Use with Battery Simulator output to protect for accidental connection to substation battery.</p> <p>Test lead, black, in-line 3.15 A fuse protection, 200 cm long (78.7")568025</p>
	<p>In-Line Resistor Test Lead: Use with old solid state relays with "leaky" SCR trip gates</p> <p>Test lead, red, in-line 100 k Ohm resistor, use with test leads up to 1000 V/ 32 Amps CAT III500395</p>
	<p>Parallel Test Lead Adapter: Used when paralleling up to three current test leads together to a common test point. Usually used when connecting to a test paddle or relay terminal.</p> <p>Parallel test lead adapter, use with test leads up to 600 V/ 32 Amps CAT II1002-286</p>
	<p>GPS unit with accessories</p> <p>GPS unit with all-weather antenna, power supply, and 15 meter cable MGTR-II-50</p> <p>GPS unit with all-weather antenna, power supply, and 30 meter cable MGTR-II-100</p>
	<p>Soft-Sided Carry Case: The soft-sided carry case protects the unit from light rain and dust. The padded sides provide moderate protection while in transit.</p> <p>Soft-sided carry case (1ea)2007-218</p>
	<p>Hard-Sided Transit Case: Includes custom designed foam inserts for the FREJA 549 unit, and accessories. Transit case includes retractable handle, built-in wheels, twist and lock-down latches, spring loaded fold-down handles, with O-ring seal.</p> <p>Rugged, hard-sided transit case (1ea)1007-363</p>

UK

Archcliffe Road Dover
CT17 9EN England
T +44 (0) 1304 502101
F +44 (0) 1304 207342
UKsales@megger.com

UNITED STATES

4271 Bronze Way
Dallas TX 75237-1019 USA
T 800 723 2861 (USA only)
T +1 214 333 3201
F +1 214 331 7399
USsales@megger.com

OTHER TECHNICAL SALES OFFICES

Valley Forge USA, College Station USA,
Sydney AUSTRALIA, Danderyd SWEDEN,
Ontario CANADA, Trappes FRANCE,
Oberursel GERMANY, Aargau SWITZERLAND,
Kingdom of BAHRAIN, Mumbai INDIA,
Johannesburg SOUTH AFRICA, Chonburi THAILAND

CERTIFICATION ISO

Registered to ISO 9001:2008 Cert. no. Q 09290
Registered to ISO 14001:2004 Cert. no. EMS 61597

FREJA549_DS_EN_V03

www.megger.com

Megger is a registered trademark