

ISOMETER® isoEV425 with coupling device AGH420

Insulation monitoring device for unearthed DC circuits (IT systems)
for charging electric vehicles



ISOMETER® isoEV425 with coupling device AGH420

Insulation monitoring device for unearthed DC circuits (IT systems)
for charging electric vehicles



ISOMETER® isoEV425

Device features

- Monitoring for DC charging stations (mode 4 according to IEC 61851-23) for charging electric vehicles
- Mains voltage measurement (r.m.s.) with under-/overvoltage detection
- DC voltage measurement to earth (L+/PE and L-/PE)
- Automatic adaptation to the system leakage capacitance up to 5 µF
- Automatic device self-test with connection monitoring
- Selectable start-up delay, response delay and delay on release
- Two separately adjustable response value ranges of 1...500kΩ (Alarm 1, Alarm 2)
- Alarm signalling via LEDs (AL1, AL2), a display and alarm relays (K1, K2)
- N/C operation or N/O operation selectable
- Measured value indication via multi-functional LCD
- Fault memory can be activated
- RS-485 (galvanically isolated) including the following protocols:
 - BMS interface (Bender measuring device interface) for data exchange with other Bender components
 - Modbus RTU
 - IsoData (for continuous data output)
- Password protection to prevent unauthorised parameter changes

Approvals and certifications



Product description

The ISOMETER®s of the isoEV425 series monitor the insulation resistance of unearthed AC/DC main circuits (IT systems) with nominal system voltages of 3(N)AC, AC, AC/DC 0...690 V or DC 0...1000 V. The main application fields are unearthed DC charging stations (mode 4 according to IEC 61851-23) for electric vehicles (IT systems) with nominal system voltages of DC 0...1000 V.

Due to a separate supply voltage, de-energised systems can also be monitored.

Application

- DC charging stations for electric vehicles according to IEC 61851-23

Function

The currently measured insulation resistance is indicated on the LC display. The ISOMETER®s are factory-set to two response values 100/500 kΩ. If the reading is below the selected response value, the response delay "t_{on}" begins. Once the response delay "t_{on}" has elapsed, the alarm relays "K1/K2" switch and the alarm LEDs "AL1/AL2" light up. By means of the two isolated response values/alarm relays, messages can be evaluated separately. If the insulation resistance exceeds the release value (response value plus hysteresis), the alarm relays switch back to their initial position.

The point of fault L+, L- or the symmetrical insulation resistance is indicated on the display. In the menu, the alarm relays can also be assigned to the point of fault.

By activating the fault memory, the alarm relays and alarm LEDs remain in alarm state until the reset button is pressed or the supply voltage is disconnected. The device functions can be checked using the test button. Parameters are assigned to the device via the LCD and the control buttons on the front panel, as well as the BMS or Modbus RTU Interface.

Connection monitoring

The connections to the electrical system (L1/+ / L2/-) and earth (E/KE) as well as the connecting wires from the Isometer® to the coupling device are periodically monitored every 24 hours after pressing the test button and connecting the supply voltage. In case of interruption of a connecting wire, the alarm relay K2 switches, the LEDs ON//AL1//AL2 flash and a message appears on the LC display as follows:

"E.0x" for a fault in the connecting wires between both devices or system fault,

"E.02" for a fault in the connecting wires to the system,

"E.01" for a fault in the connecting wires to PE.

After eliminating the fault, the alarm relays return to their initial position either automatically or by pressing the reset button.

Measurement method

The ISOMETER® isoEV425 works with different measurement methods adapted to the application with a maximum response time of 10 s.

Standards

The ISOMETER® isoEV425 series meets the device standards:
DIN EN 61557-8 (VDE 0413-8), IEC 61557-8

Operating elements

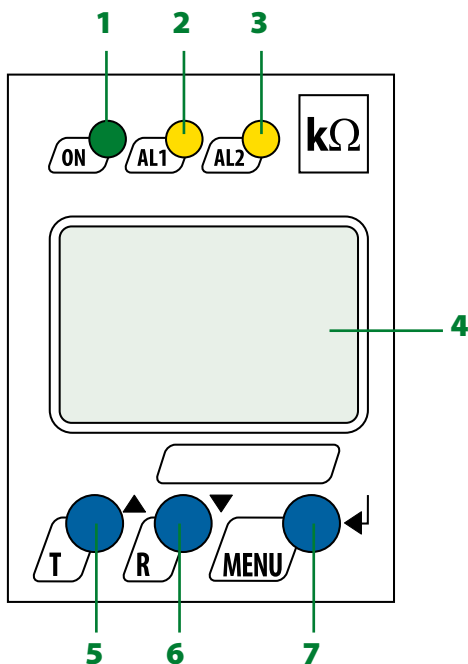

- 1 - LED "ON" (operation LED) flashes in case of interruption of the connecting wires E/KE or L1/+ / L2/- or system fault.
- 2 - Alarm LED "AL1", lights when the values fall below the set response value Alarm 1 and flashes in case of interruption of the connecting wires E/KE or L1/+ / L2/-, or system faults as well as in the case of overvoltage (can be activated).
- 3 - Alarm LED "AL2" lights when the values fall below the set response value Alarm 2 and flashes in case of interruption of the connecting wires E/KE or L1/+ / L2/- or system faults as well as in the case of undervoltage (can be activated).
- 4 - LC display
- 5 - Test button "T": Call up the self-test
Arrow up button: Parameter change, move upwards in the menu
- 6 - Reset button "R": Delete stored insulation fault alarms
Arrow down button: Parameter change, move downwards in the menu
- 7 - Menu button "MENU": Call up the menu system.
Enter button: Confirms parameter changes

Wiring diagram

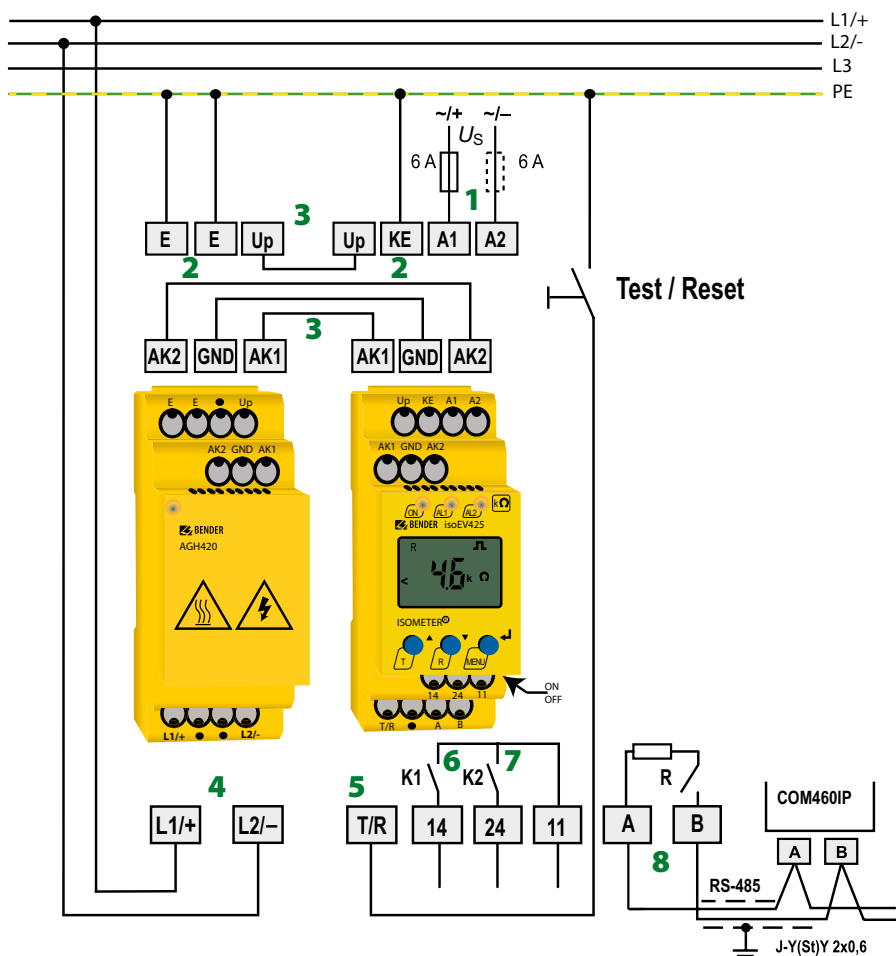

- 1 - Connection to the supply voltage via fuse (line protection). If being supplied from an IT system, both lines have to be protected by a fuse.
- 2 - Connect each terminal separately to PE: The same wire cross section as for A1, A2 must be used
- 3 - Connect the terminals of AGH420 to the corresponding terminals of the isoEV425
- 4 - Connection to the 3(N)AC, AC or DC system to be monitored
- 5 - Connection for the external combined test and reset button.
- 6 - Connection to alarm relay K1
- 7 - Connection to alarm relay K2
- 8 - Connection RS-485 (BMS bus) with termination switch R (on/off)
Example: Connection of a BMS-Ethernet Gateway COM460IP.

Technical data ISOMETER® isoEV425

Insulation coordination acc. to IEC 60664-1/IEC 60664-3

Rated voltage (A1, A2) - (11, 14, 24)	300 V
Rated impulse voltage	4 kV
Overtoltage category	III
Pollution degree	3
Protective separation (reinforced insulation) between (A1, A2) - (AK1, GND, AK2, Up, KE, T/R, A, B) - (11, 14, 24)	
Voltage tests according to IEC 61010-1	2.2 kV

Supply voltage

Supply voltage U_S	AC 100...240 V/DC 24...240 V
Tolerance of U_S	-20...+15 %
Frequency range U_S	47...63 Hz
Power consumption	≤ 3 W, ≤ 9 VA

IT system being monitored

Nominal system voltage U_n with AGH420	3(N)AC, AC 0...690 V/DC 0...1000 V
Tolerance of U_n	AC + 15 %, DC + 10 %
Nominal system voltage range U_n with AGH420 (UL508)	AC/DC 0...600 V
Frequency range of U_n	DC, 40...460 Hz

Measuring circuit

Permissible system leakage capacitance C_e	≤ 5 μ F
Permissible extraneous DC voltage U_{fg}	≤ 1150 V

Response values

Response value R_{an1}	2...500 k Ω (500 k Ω)*
Response value R_{an2}	1...490 k Ω (100 k Ω)*
Relative uncertainty R_{an}	± 15 %, at least ± 1 k Ω
Hysteresis R_{an}	25 %, at least 1 k Ω
Undervoltage detection	30 V...1.14 kV (off)*
Overtoltage detection	31 V...1.15 kV (off)*
Relative uncertainty U	± 5 %, at least ± 5 V
Relative uncertainty depending on the frequency ≥ 200 Hz	-0.03 %/Hz
Hysteresis U	5 %, at least 5 V

Time response

Response time t_{an} at $R_F = 0.5 \times R_{an}$ and $C_e = 1 \mu$ F acc. to IEC 61557-8	≤ 10 s
Start-up delay t	0...10 s (0 s)*
Response delay t_{on}	0...99 s (0 s)*
Delay on release t_{off}	0...99 s (0 s)*

Displays, memory

Indication	LC display, multifunctional, not illuminated
Display range measured value insulation resistance (R_F)	1 k Ω ...1 M Ω
Operating uncertainty at $R_F \leq 1$ M Ω	± 15 %, at least ± 1 k Ω
Display range measured value nominal system voltage (U_n)	30 V...1.15 kV rms
Operating uncertainty	± 5 %, at least ± 5 V
Relative uncertainty depending on the frequency ≥ 200 Hz	-0.03 %/Hz
Display range measured value system leakage capacitance at $R_F > 10$ k Ω	0...10 μ F
Operating uncertainty	± 15 %, at least ± 2 μ F
Password	off/0...999 (0, off)*
Fault memory alarm messages	on/(off)*

Interface

Interface/protocol	RS-485/BMS, Modbus RTU, isoData
Baud rate	BMS (9.6 kbit/s), Modbus RTU (selectable), isoData (115,2 kbits/s)
Cable length (9.6 kbits/s)	≤ 1200 m
Cable: twisted pair, one end of shield connected to PE	recommended: min. J-Y(St)Y 2x0.6
Termination resistor	120 Ω (0.25 W), internal, can be connected
Device address, BMS bus, Modbus RTU	3...90 (3)*

Switching elements

Switching elements	2 x 1 N/O contact, common terminal 11
Operating principle	N/C or N/O operation (N/O operation)*
Electrical endurance in rated operating conditions	10 000 cycles
Contact data acc. to IEC 60947-5-1:	
Utilisation category	AC-12 AC-14 DC-12 DC-12 DC-12
Rated operational voltage	230 V 230 V 24 V 110 V 220 V
Rated operational current	5 A 2 A 1 A 0.2 A 0.1 A
Minimum contact rating	1 mA at AC/DC ≥ 10 V

Environment/EMC

EMC	IEC 61326-2-4
Ambient temperatures:	
Operation	-40...+70 °C
Transport	-40...+80 °C
Storage	-40...+70 °C
Classification of climatic conditions acc. to IEC 60721	
Stationary use (IEC 60721-3-3)	3K7 (except condensation and formation of ice)
Transport (IEC 60721-3-2)	2K4 (except condensation and formation of ice)
Long-term storage (IEC 60721-3-1)	1K5 (except condensation and formation of ice)
Classification of mechanical conditions acc. to IEC 60721	
Stationary use (IEC 60721-3-3)	3M4
Transport (IEC 60721-3-2)	2M2
Long-term storage (IEC 60721-3-1)	1M3

Connection

Connection type	push-wire terminal
Nominal current	≤ 10 A
Conductor sizes	AWG 24-14
Stripping length	10 mm
Connection properties:	
Rigid/flexible	0.2...2.5 mm ²
Flexible with ferrule with/without plastic sleeve	0.25...2.5 mm ²
Multiple conductor flexible with TWIN ferrule with plastic sleeve	0.5...1.5 mm ²
Opening force	50 N
Test opening, diameter	2.1 mm
Wiring of the terminals Up, AK1, GND, AK2	refer to technical data AGH420, under the heading "Connection"

Other

Operating mode	continuous operation
Mounting	cooling slots must be ventilated vertically
Degree of protection, internal components (IEC 60529)	IP 30
Degree of protection, terminals (IEC 60529)	IP 20
Enclosure material	polycarbonate
DIN rail mounting acc. to	IEC 60715
Screw mounting	2 x M4 with mounting clip
Documentation number	D00126
Weight	≤ 150 g

()* = factory setting

Technical data coupling device AGH420

Insulation coordination acc. to IEC 60664-1/IEC 60664-3

Rated insulation voltage	1000 V
Rated impulse voltage	8 kV
Pollution degree	3
Overtoltage category	III
Protective separation (reinforced insulation) between	(L1/+, L2/-) - (AK1, GND, AK2, Up, E)
Voltage test, routine test (IEC 61010-1)	4.3 kV

IT system being monitored

Nominal system voltage range U_n	AC/DC 0...1000 V
Tolerance of U_n	AC/DC +10 %
Nominal system voltage range U_n (UL508)	AC/DC 0...600 V

Measuring circuit

Measuring voltage U_m	± 45 V
Measuring current I_m at R_f	≤ 400 μA
Internal DC resistance R_i	≥ 120 kΩ

Environment/EMC

EMC	IEC 61326-2-4
Ambient temperatures:	
Operation	-40...+70 °C
Transport	-40...+80 °C
Storage	-40...+70 °C
Classification of climatic conditions acc. to IEC 60721:	
Stationary use (IEC 60721-3-3)	3K7 (except condensation and formation of ice)
Transport (IEC 60721-3-2)	2K4 (except condensation and formation of ice)
Long-term storage (IEC 60721-3-1)	1K5 (except condensation and formation of ice)
Classification of mechanical conditions acc. to IEC 60721:	
Stationary use (IEC 60721-3-3)	3M4
Transport (IEC 60721-3-2)	2M2
Long-term storage (IEC 60721-3-1)	1M3

Connection

Connection type	push-wire terminal
Nominal current	≤ 10 A
Conductor sizes	AWG 24-14
Stripping length	10 mm
Connection properties:	
Rigid/flexible	0.2...2.5 mm ²
Flexible with ferrule with/without plastic sleeve	0.25...2.5 mm ²
Multiple conductor flexible with TWIN ferrule with plastic sleeve	0.5...1.5 mm ²
Opening force	50 N
Test opening, diameter	2.1 mm
Connection type	terminals Up, AK1, GND, AK2
Single cables for terminals Up, AK1, GND, AK2: Cable lengths	≤ 0.5 m
Connection properties	≥ 0.75 mm ²

Other

Operating mode	continuous operation
Mounting	cooling slots must be ventilated vertically
Distance to adjacent devices from $U_n > 800$ V	≥ 30 mm
Degree of protection, internal components (IEC 60529)	IP 30
Degree of protection, terminals (IEC 60529)	IP 20
Enclosure material	polycarbonate
DIN rail mounting acc. to	IEC 60715
Screw mounting	2 x M4 with mounting clip
Weight	≤ 150 g

(*) = factory setting

Ordering information

Supply voltage ¹⁾ U_S		Type	Art. no.
AC	DC		
100...240 V, 47...63 Hz	24...240 V	isoEV425-D4-4 with AGH420	B 7103 6401

Device version with screw terminals on request. ¹⁾ Absolute values

Accessories

Description	Art. no.
Mounting clip for screw mounting (1 piece per device)	B 9806 0008

Dimension diagram XM420

Dimensions in mm

Open the front plate cover in direction of arrow!

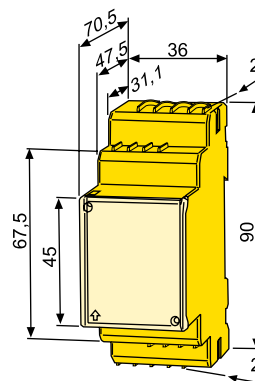

Screw mounting

Note: The above mounting clip is an accessory and must be ordered separately (see accessories).

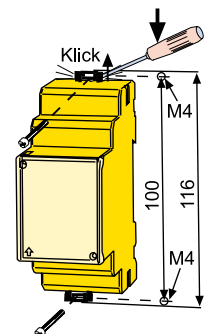

Example of application

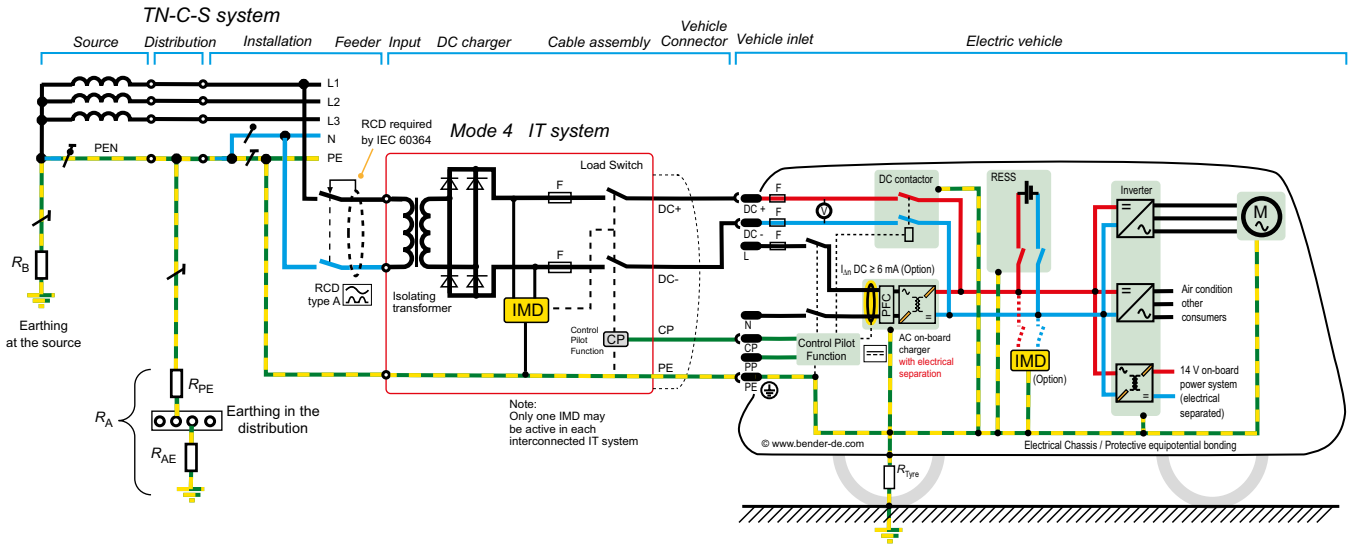

Bender GmbH & Co. KG
 P.O. Box 1161 • 35301 Gruenberg • Germany
 Londorfer Straße 65 • 35305 Gruenberg • Germany
 Tel.: +49 6401 807-0 • Fax: +49 6401 807-259
 E mail: info@bender.de • www.bender.de



BENDERGroup