



CC612 Charge Controller

CC612 Charge Controller

This quick-start guide does not replace the operating manual, which is available under www.bender.de/manuals.



Risk of fatal injury from electric shock!

Any work on electrical installations which is not carried out properly can lead to death and injury! Only skilled persons are permitted to carry out the work necessary to install, commission and run a device or system.

The CC612 charge controller should only be used for its intended purpose.

Intended use

The CC612 charge controller is the main component of a charge system and is designed for use in electric vehicle (EV) charging stations, wall boxes and street light charging points. The charge controller controls type 1 and type 2 plugs, and type 1 and type 2 sockets. It enables a setup that is in accordance with current standards, such as IEC 62196, IEC 61851-1, IEC 61851-22 and IEC 60364-7-722.

Product description

The charge controller monitors charge system internal hardware, such as the meter, the user interface board or the socket. Several product variants are available. Some of them can connect to a digital eHZ meter using an optical interface while others can read Modbus meters. These variants can optionally read meters with an S0 interface. Further charge controller variants feature an integrated DC sensor which uses an externally connected and shielded current transformer for the fault monitoring of AC charging systems. This means that only a type A RCD is required in the charging system. The charge controller features two USB interfaces – one for local configuration (CONFIG) and the other as an extension port for peripheral USB devices (home networking). In addition, a configurable 3-channel input/output extension interface is available for additional functionality.

To enable the charge controller to communicate online, a backend system is required. The charge controller is OCPP compliant. All specified messages in OCPP are supported as well as some vendor-specific extensions based on the DataTransfer message. The CC612 can be operated as an "always on" system that is always connected to a mobile network. The controller supports 2.5G Edge and 3G UMTS mobile networks. Connectivity for online operation requires a SIM card (which is not included in delivery). User interaction is facilitated using an RFID module, which consists of an RFID card reader and LEDs. The RFID module is described in a separate operating manual, which is available under www.bender.de/manuals. Charging is initiated by holding a valid RFID card close to the reader. In offline operation, the charge controller can optionally allow charging without authorization or it can authorize users based on RFID and a local "white list" of authorized RFID cards.

Dimensions and installation

DIN rail mounting

Fix the charge controller onto the DIN rail by pulling down the silver-coloured mounting clip (indicated in photo below). Position the charge controller and release the clip to allow the device to sit securely on the rail.

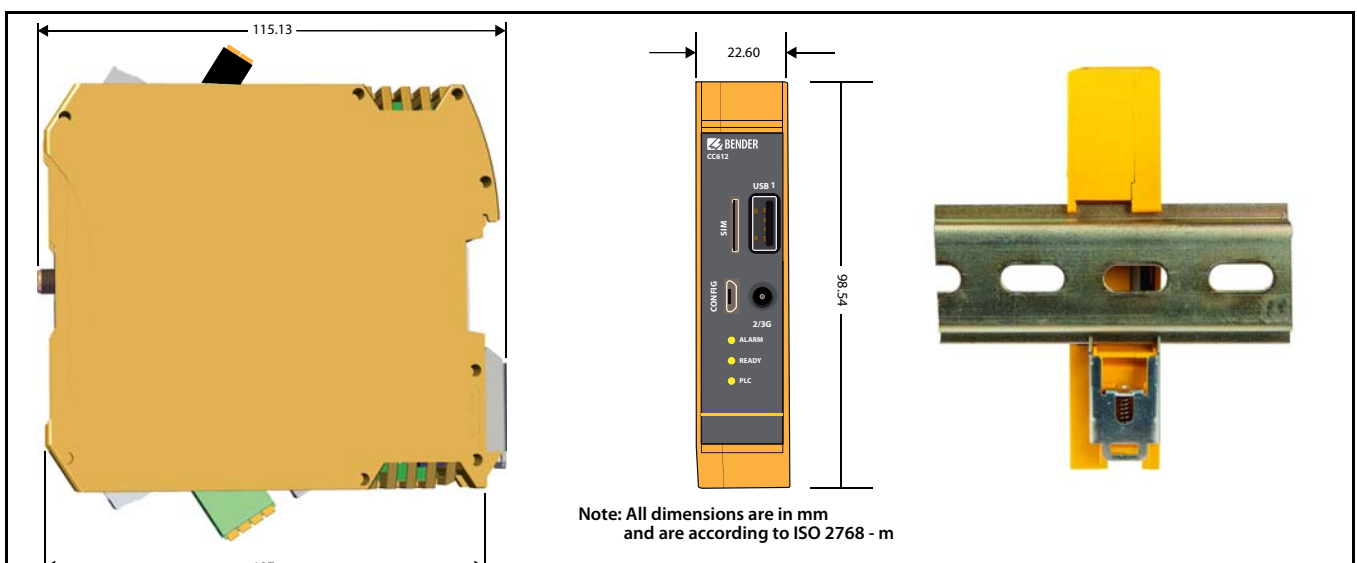

Connection



Risk of electric shock!

Even though the charge controller terminals have nominal voltages measuring up to 12 V, the charge system voltage is 230 V. Touching live parts of the system carries the risk of electric shock.



The IEC 61851 standard requires that the reference level of the CP communication is at same level as the power supply, i.e. protective earth (PE) must be connected to 0 V.

The charge controller connections for all device variants are shown below.

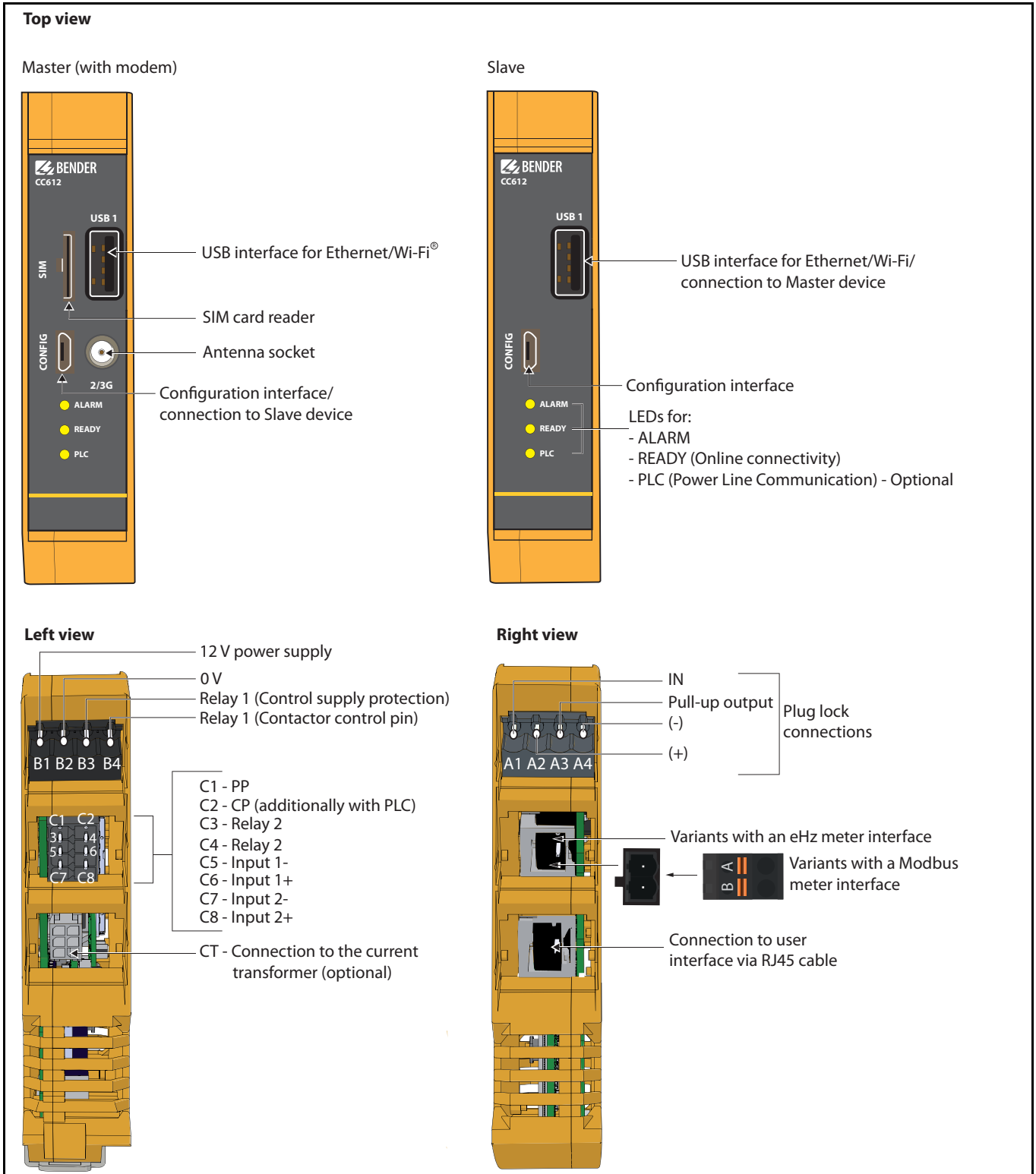

Connect the charge controller as shown in the wiring diagram below:

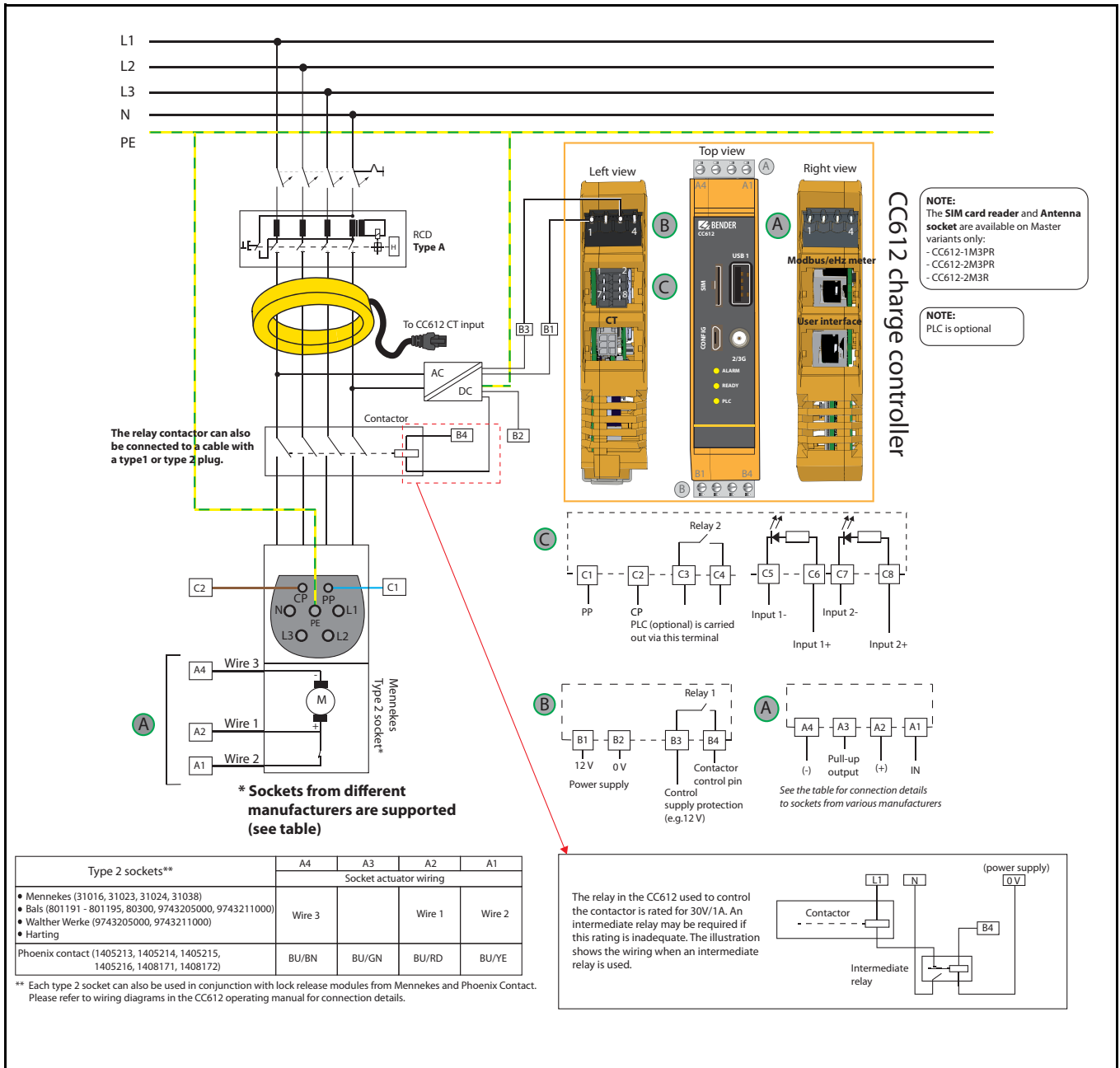

Configuration

The charge system can be configured:

- **Locally** whereby the charge controller provides a web interface via the micro USB configuration interface (CONFIG)
- USB Ethernet/WLAN interface via a USB Ethernet dongle or USB Wi-Fi® (USB 1) or via the 3G Modem
- **Remotely** by utilizing the ChangeConfiguration command of the OCPP protocol

Local configuration and parameters

To locally configure the charge system via the charge controller, connection with a micro USB cable to a laptop, PC or tablet computer with a normal USB host interface is required. Once connected, the charge controller is recognised as a USB network adapter.



The CC612 must be powered with 12 V when the CONFIG interface is being used.

USB configuration interface

The USB configuration interface, CONFIG, emulates a so-called Remote Network Driver Interface Specification (RNDIS) network when it is plugged into Windows, Linux or Mac OS computers. In a Linux and Mac OS, this virtual network interface is automatically detected and a driver is not necessary. On a Windows host machine, however, the driver for the RNDIS network adapter usually needs to be manually selected. To do this:

- Open the device manager from the control panel
- Right click the "RNDIS/Ethernet Gadget" menu item located under "Other devices" and select "Update Driver Software"
- Select the option "Browse my computer for driver software".
- Then click on the option "Select from a list of device drivers on my computer".
- From the list presented, select the "Network adapters" category.
- In the window that appears, select the manufacturer Microsoft Corporation and the network adapter "Remote NDIS Compatible Device". The device driver is then installed and the system recognises the charge controller as a network adapter.

The charge controller uses the local IP address 192.168.123.123 with a subnet mask of 255.255.255.0 on the virtual network interface corresponding to the USB configuration interface. The PC (or target) is automatically assigned a corresponding IP address via the Dynamic Host Configuration protocol (DHCP) once it is connected and communication with the charge system is based on this IP address.

- The Charge System Control Interface **State page** is accessed using the URL <http://192.168.123.123> and shows status information only.
- The Charge System Control Interface **Operator page** is accessed using the URL <http://192.168.123.123/operator>. As well as showing status information, operator parameters can be set. (Username: operator; Password: yellow_zone)
- The Charge System Control Interface **Manufacturer page** is accessed using the URL <http://192.168.123.123/manufacturer>. As well as showing status information, operator and manufacturer parameters can be set. (Username: manufacturer; Password: orange_zone)

These default passwords can be changed. The manufacturer can also change the user passwords and operating parameters. Each of the charge controller parameters are adequately described on the respective web interface pages.

Parameter changes are not always applied after submission. To submit all changed parameters, click the "**Save & Restart**" button at the bottom of the page.

Master/Slave connection

The charge controller can function as a Master (the dedicated controller is switched into Master mode) or Slave. Master/Slave operation can be configured by connecting the USB configuration interface of one charge controller (Master device) to a USB interface for Ethernet/Wi-Fi® of the second charge controller (Slave device) using a USB cable.

One Slave can connect to the Master controller. The communication protocol is binary OCPP 1.6. Essentially the Master controller becomes the OCPP backend for the Slave controller. The Master controller exposes each Slave as an additional connector to the backend. A charge controller is assigned the Master and Slave role on the **Manufacturer page**. Each Slave controller then needs to be assigned the IP address of the Master controller as its binary OCPP hostname and needs to use port 1600 as the binary OCPP port to connect to the Master. Multiple connectivity technologies to connect Master and Slave can be used, for example Ethernet and, where available, Wi-Fi®. The Master is assigned an additional USB address of 192.168.125.124 on the **Operator configuration** page without assigning a standard gateway. The Slave uses the IP 192.168.125.125 to connect to the Master. Using USB as the connection technology like this is more cost efficient than using multiple Ethernet dongles or Wi-Fi® but limits the distance of the controllers to a few meters as the maximum length of a USB cable is 5 meters. The Slave configuration web page (e.g. <http://192.168.123.123>) then offers links to access the Master and the Slave configuration.

DC sensor

Current Transformer (CT) connection (device variant)

For AC charging system fault monitoring, a charge controller variant is available which features an integrated DC sensor which works with an external magnetically shielded measuring current transformer (CT) connected to the CC612. This allows the use of a type A RCD in the charging system instead of the more expensive type B RCD. The relays in the CC612 are triggered if, during charging, the fault current limit $I_{\Delta n} \geq DC \ 6 \text{ mA}$.



The charge controller only works in combination with the measuring current transformer (which must be ordered separately).

I/O extension

The CC612 has additional I/O interfaces available via a configurable 3-channel I/O interface (**connector C: C3-C8**) that can be used for multiple purposes, for example:

- Parking management interface (The supported communication protocol is proprietary to Scheidt & Bachmann and based on the available auxiliary relay and one available input)
- Additional household main socket outlet control
- Power outage monitoring (e.g. RCD trip monitoring)
- Cooling fan switch for over-temperature control
- Connection to meters with an S0 interface

Connection to lock release modules

Each type 2 socket can also be used in conjunction with lock release modules from various manufacturers. Refer to the operating manual for further details.

Boot-up

The boot-up process begins once 12 V is supplied to the charge controller. After about 30 s, the ALARM, READY and PLC LEDs, visible on the front panel, light up. After some time the three LEDs are turned off and only the "READY" LED blinks, indicating a successful boot-up. At the same time, the "Free" LED on the RFID module (if configured) lights continuously, marking the end of the boot up sequence.

Connectivity to the backend



An antenna socket connects to a GSM/UMTS antenna. The approved external antenna, the Phoenix contact Model PSIGSM/UMTS-QB-ANT-2313371 must be used in order to receive GSM and UMTS signals.

via 2.5/3G modem

The system should be able to establish an online connection to the backend system after another 20 to 120 s. In addition, the SIM card, inserted into the charge controller SIM card reader, is activated. If a SIM card PIN number is required, it needs to be configured on the Charge System Control Interface operator page otherwise a backend connection will not be possible. With a data network connection established, the charge system is now available. The APN settings for the card can also be configured via the internal configuration web interface.

via a USB Ethernet adapter or USB Wi-Fi® (USB 1)

If Ethernet is connected to a valid network during boot-up of the charge controller, and a DHCP Server exists in this network, the charge controller obtains an IP address from the DHCP server. The IP address provided to the charge controller can be influenced by assigning a fixed IP address for the charge controller at the DHCP server in your network. This IP address can then be used to make a connection. In addition, the charge controller always uses a second IP address: 192.168.124.123 in the subnet 255.255.255.0 - on the Ethernet interface.



If there is no DHCP server in your network or it was connected during boot-up or you have no means of determining the IP address assigned via DHCP, then assign an IP address from the 192.168.124.x subnet to your PC, connect it to the same Ethernet subnet and connect to the charging system using the 192.168.124.123 IP address.

eHz/Modbus/S0 meter connectivity

- The eHz meter is read by an optical reader attached to the mounting plate of the meter so that it can interface with the optical interface on the back of the meter. The optical reader is then connected to the charge controller with an RJ10 plug.
- Modbus RTU can be used instead of an RS-485 based eHZ interface to connect to Modbus meters. Various Modbus meters are currently supported and are listed on the webserver **Operator** page.
- Meters with an S0 interface can be attached to one of the available inputs on connector C.

Refer to the webserver **State** page to check if the eHz and Modbus meters have been successfully connected. In the case of meters with an S0 interface, values are only displayed when charging takes place.

Connectivity to the user interface

A simple user interface is intended for customer-specific applications, such as:

- **RFID module RFID110-L1** - The RFID module is a separate PCB and is designed according to ISO14443A/MIFARE. It is connected to the charge controller using a standard RJ45 cable
- **Display module DPM2x16FP** - The display module is used to indicate the charge controller status information as well as the charging status. It features two RJ45 cable sockets, one which connects to the charge controller and the other which can connect to the RFID module.



The RFID and Display modules are described in separate operating manuals, which can be downloaded from www.bender.de/manuals.

Plug locking and unlocking

After boot-up and a successful online connection, plug locking and unlocking can be tested to see if the type 2 socket was correctly attached to the charge controller.

- First insert a plug that connects the charge system with a vehicle into the type 2 socket. The socket should automatically lock the plug. This locking action can normally be heard. Test by gently pulling on the plug.
- To unlock the plug, first disconnect the plug from the vehicle. This action automatically unlocks the charge system socket, allowing the cable to be removed.

Via terminals A1 ... A4 (i.e. plug lock connections), the charge controller can interface to different socket/actuator types. Refer to the wiring diagram on [page 3](#).

Charging

After ensuring that a vehicle has been successfully connected to the charge system, charging is initiated by holding an RFID card, registered with the backend system, close to the RFID module. Charging starts when the contactor is switched on to provide power flow

Geographical application

Variants with an integrated 3G modem may be operated in the following countries only:

Austria, Andorra	Latvia, Liechtenstein, Lithuania, Luxembourg
Belgium, Bulgaria	Malta, Monaco, Martinique, Madeira
Croatia, Cyprus, Czech Republic, Canary Islands, Canada	Norway
Denmark	Poland, Portugal
Estonia	Romania, Réunion
Germany, Great Britain, Greece, Guadeloupe	Slovakia, Slovenia, Spain, Sweden, Switzerland, San Marino, Saint Martin
Finland, France, French Guyana	Turkey, The Azores
Holland, Hungary	USA
Iceland, Ireland, Italy	

Technical Data

Insulation coordination acc. to IEC 60664-1/IEC 60664-3

Rated voltage	12.5 V
Overvoltage category/Pollution degree	III/3
Rated impulse withstand voltage	800 V
Altitude	≤ 2000 m AMSL

Supply voltage

Nominal supply voltage	DC 12 V
Operating range of the supply voltage	DC 11.4 . . . 12.6
Nominal current	1 A

Measuring range DC sensor

Measuring range	100 mA
-----------------	--------

Response values:

Residual current $I_{\Delta n}$	DC 6 mA
Response tolerance $I_{\Delta n}$	-50 . . . 0 %

Restart sequence value:

DC 6mA	< 3 mA
--------	--------

Wireless parameters

Frequency bands	850/900/1800/1900/2100 MHz
Antenna gain	≤ 2.5 dBi
Impedance	50 Ω
Data rate	GPRS: UL 85.6 kBit/s; DL 85.6 kBit/s EDGE: UL 236.8 kBit/s; DL 236.8 kBit/s WCDMA PS: UL 384 kBit/s; DL 384 kBit/s HSPA: UL 5.76 MBit/s; DL 14.4 MBit/s
Specified antenna	Phoenix Contact model PSI-GSM /UMTS-QB-ANT-2313371

Inputs/outputs and operation

LED ALARM	yellow
LED READY	green
LED PLC	green
USB Extension interface (Ethernet, Wi-Fi®, . . .)	USB socket type A
CONFIG (Configuration interface)	Micro socket type AB
SIM card	micro SIM

Terminal A:

A1	Actuator IN
A2	Actuator +
A3	Actuator pull-up output
A4	Actuator -

Terminal B:

B1	+12 V IN
B2	0 V
B3	Relay 1 NO
B4	Relay 1 NO

Terminal C:

C1	Proximity PP
C2	Control Pilot (optional Powerline Communication PLC acc. to ISO/IEC 15118)
C3	Relay 2 NO
C4	Relay 2 NO
C5	Input 1-
C6	Input 1+

C7	Input 2-
C8	Input 2+
CT	Current transformer

Input 1 and Input 2 :

Input voltage	DC 11.4 V . . . 25.2 V
Input current	1.72 . . . 3.81 mA

Meter	Meter interface
User interface	User interface RJ45

Switching elements

Relay 1	configurable
Relay 2	charging contactor
Switching elements	2 x 1 N/O contacts
Operating principle	N/C operation
Electrical service life	10,000 switching cycles

Contact data acc. to IEC 60947-5-1:

Rated operational voltage U_e	30 V
Rated operational current I_e	1 A
Minimum contact rating	1 mA at ≥ 10 V
Rated voltage U_i	32 V

Environment/EMC

EMC (ETSI for Master only)	IEC 61851-1, IEC 61851-22, ETSI EN 301 489-1, ETSI EN 301 489-7
Operating temperature	-30 . . . +70°C

Climatic conditions acc. to IEC 60721:

Stationary use (IEC 60721-3-3)	3K5 (No condensation, no water and no formation of ice)
Transport (IEC 60721-3-2)	2K2
Long-term storage (IEC 60721-3-1)	1K2

Mechanical conditions acc. to IEC 60721:

Stationary use (IEC 60721-3-3)	3M4
Transport (IEC 60721-3-2)	2M2
Long-term storage (IEC 60721-3-1)	1M3

Connection

Connection type (terminal block C) push-wire terminal

Connection properties:	
rigid/flexible	0.2 . . . 1.5 mm ² (AWG 24 . . . 16)
flexible with ferrule without plastic sleeve	0.25 . . . 1.5 mm ² (AWG 24 . . . 16)
flexible with ferrule with plastic sleeve	0.25 . . . 0.75 mm ² (AWG 24 . . . 20)
Stripping length	10 mm
Opening force	0.5 - 0.6 Nm (4 . . . 5 lb-in)

Connection type (terminal blocks A and B) screw terminal

Connection properties:	
rigid/flexible	0.2 . . . 2.5 mm ² (AWG 24 . . . 12)
flexible with ferrule without plastic sleeve	0.25 . . . 2.5 mm ² (AWG 24 . . . 14)
flexible with ferrule with plastic sleeve	0.25 . . . 1.5 mm ² (AWG 24 . . . 16)
Stripping length	7 mm
Tightening torque	0.5 - 0.6 Nm (4 . . . 5 lb-in)

Other

Operating mode	continuous operation
Degree of protection	IP 20
DIN rail mounting	IEC 60715
Weight	160 g

All rights reserved. Reprinting and duplicating only with
permission of the publisher. Subject to change!

© Bender GmbH & Co. KG

Photos: Bender archives.

Bender GmbH & Co. KG
Postbox 1161 • 35301 Grünberg • Germany
Londorfer Straße 65 • 35305 Grünberg • Germany
Tel.: +49 6401 807-0 • Fax: +49 6401 807-259
E-Mail: info@bender.de • www.bender.de



BENDER Group